



200 Shadylane Drive
Philipsburg, PA 16866

Phone: (814) 342-6205
Fax: (814) 342-4510
www.druckerdiagnostics.com

Service Manual

Model Dash Apex 6 Centrifuge

Model Dash Flex 6 Centrifuge

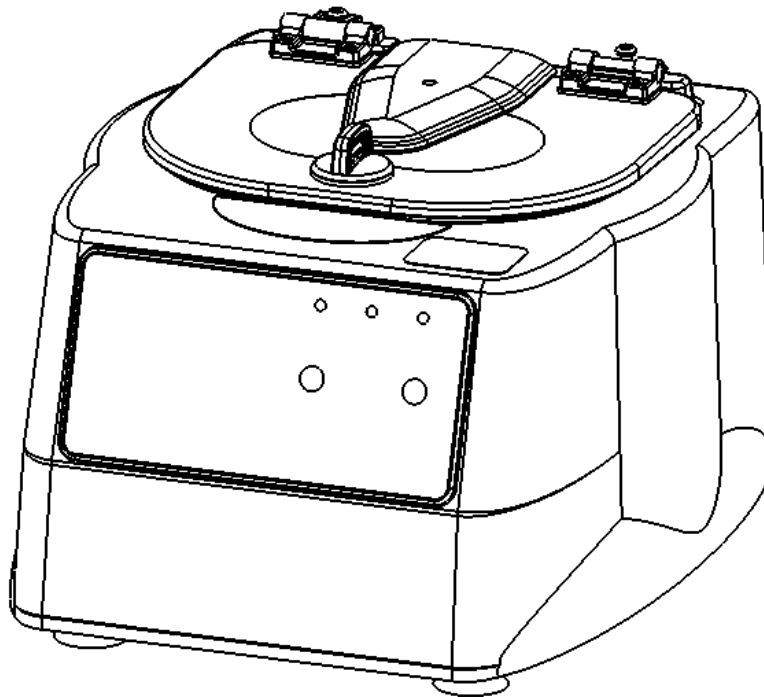

CONTENTS

1 PREFACE..... 1

2 GENERAL DESCRIPTION OF MAJOR COMPONENTS 1

3 WARRANTY INFORMATION 1

4 SPECIFICATIONS..... 1

5 TROUBLESHOOTING 2

6 SERVICE INSTRUCTIONS..... 2

7 ASSEMBLY DRAWINGS – Dash Apex 6 Centrifuge..... 7

8 ASSEMBLY DRAWINGS – Dash Flex 6 Centrifuge..... 11

9 REVISION HISTORY..... 15

1 PREFACE

- 1.1 The purpose of this manual is to provide the service technician with information for troubleshooting, testing, and repair of laboratory centrifuge model Apex 6. Only qualified technically trained personnel should attempt any of the servicing described in this document. Failure to follow the procedures in this document may result in personal injury or instrument damage. Drucker Diagnostics will not be held liable for any injury or damage as a result of improper servicing.
- 1.2 Information contained within this manual is subject to change without notice.

2 GENERAL DESCRIPTION OF MAJOR COMPONENTS

- 2.1 Motor: Brushless DC Motor
- 2.2 Printed Circuit Board: The PCB is the microcontroller based control center of the centrifuge. All control signals are generated in the PCB.
- 2.3 Lid Locking Tray Assembly: The lid tray assembly contains a solenoid and limit switch that are used to determine the state of the lid (Open or Closed) and to keep the lid locked during centrifugation cycles.
- 2.4 Rotor: The centrifuge rotor is the main component that spins in the centrifuge. The rotor is loaded with tube holders, and the samples are placed into the tube holders for processing.

3 WARRANTY INFORMATION

- 3.1 Drucker Diagnostics warrants its centrifuges to be free from defects in workmanship and parts for two years.

4 SPECIFICATIONS

	Dash Apex 6	Dash Flex 6
Maximum Speed	5300 RPM	5350 RPM
Maximum RCF	4000 xg	4150 xg
Maximum Capacity	6 Tubes (17 x 100mm)	6 Tubes (17 x 100mm)
Dimensions (in)	9.0 (H) x 12.0 (W) x 14.0 (L)	9.0 (H) x 12.0 (W) x 14.0 (L)
Ambient Temperature	5 – 40 deg C	5 – 40 deg C
Typical Noise Level (At Maximum Speed)	< 62 dB A	< 62 dB A

Supply Voltage	100 – 240 (+/- 10%) VAC (+/- 10V) power supply input (48VDC output)	100 – 240 (+/- 10%) VAC (+/- 10V) power supply input (48VDC output)
Supply Frequency	50 – 60 Hz	50 – 60 Hz
Current Consumption	2.2A at 115VAC 1.1A at 230VAC	2.2A at 115VAC 1.1A at 230VAC

5 TROUBLESHOOTING

PROBLEM	POSSIBLE CAUSE	SOLUTION
The lid does not open.	No Power	Check line cord.
	No Power	Check external power supply.
	No Power	Check wall outlet.
	Lid knob is ajar	Rotate the lid knob fully clockwise before pressing the 'OPEN' button.
	Lid lock is active (Unlock timed out)	Press the 'OPEN' button to de-activate the lid.
	Lid tray is unplugged from PCB or defective	Requires service.
	PCB is damaged	Requires service.
		To gain access to the rotor - Remove the 'OPEN/CLOSE' sticker and slide the lid latch lever toward the front of the centrifuge. This will unlock the lid.

PROBLEM	POSSIBLE CAUSE	SOLUTION
Excessive vibration	Rotor improperly loaded	Load equally filled tubes symmetrically in the rotor. All carriers and/or tube holders must be present in the rotor, whether loaded, or empty.
	Debris lodged within the rotor or tube carriers	Carefully inspect all rotor pockets, tube holders and crevasses for debris.
	Centrifuge housing is loose	Requires service.
	Missing/damaged feet	Requires service.
	Motor failure	Requires service.
	Rotor windshield damage	Requires service.
	Rotor damaged	Replacement required.

PROBLEM	POSSIBLE CAUSE	SOLUTION
Rotor does not spin	No Power	Check line cord.
	No Power	Check external power supply.
	No Power	Check wall outlet.
	Lid not properly latched	Press down firmly on lid and rotate lid knob clockwise until the 'Locked' light illuminates.
	Internal connection failure	Requires service.
	PCB failure	Requires service.
	Motor Failure	Requires service.

PROBLEM	POSSIBLE CAUSE	SOLUTION
Clicking noise during braking	Rotor is loose	Tighten rotor screw.

PROBLEM	POSSIBLE CAUSE	SOLUTION
Whistling noise while running	Debris in air intake / exhaust ports	Remove power before clearing debris.
	Gasket failure	Requires service.
	Gasket failure	Requires service.

6 SERVICE INSTRUCTIONS

6.1 Cleaning

- a) Use appropriate Personal Protective Equipment (PPE)
- b) The cabinet, rotor top and accessories shall be thoroughly cleaned using soap and water, isopropyl alcohol, or a mild bleach solution.
- c) Apply cleaning solutions with a dampened towel or cloth ONLY. Do not spray or pour cleaning solution directly onto or into the centrifuge. Do not saturate or submerge the

centrifuge in water or other cleaning solutions as this will cause damage, create a safety risk; and void the warranty.

- d) Under no circumstances should any of the following be used: Fully/Partially Halogenated Hydrocarbons, Ketones and Esters.
- e) Use of any chemicals not prescribed by the manufacturer may cause damage to the rotor and tube carriers / holders and shall not be used.

6.2 Removing the Rotor Core

- a) Use a 1/8" hex driver to loosen the center rotor screw (turn counter-clockwise).
- b) Lift the rotor core straight up and out of the rotor chamber.
- c) To install the rotor core reverse steps A and B above.
- d) Take care to align the hub spines with the rotor cone and the tube numberings 1 through 6 with the windshield cover.
- e) Tighten the rotor screw with a 1/8" hex driver to 2.0 Nm.

6.3 Maintaining the Rotor

- a) Keep the rotor clean; any corrosive materials must not be allowed contact with the rotor and should be cleaned immediately.
- b) The rotor should be checked periodically for signs of wear.
- c) Remove the rotor from service if any of the following are found: cracks, deep scratches, corrosion or discoloring.

6.4 Rotor Screw

- a) If the rotor screw needs to be tightened, use a 1/8" hex driver and tighten to 2.0 Nm.

6.5 Speed Calibration

- a) Check the centrifuge speed periodically, at least every two years is recommended.
- b) Important: When verifying rotor speed, make certain that all tube holders are installed in the rotor.
- c) No calibration adjustment of speed can be made, only a verification of rotor speed.

6.6 Removing the Cabinet (Upper Housing)

- a) There are six screws that fasten the centrifuge cabinet to the base.
- b) Begin by unplugging the centrifuge and waiting 10 minutes for internal voltages to dissipate.
- c) Use a #2 Phillips screwdriver to remove the cabinet screws (three on the back, six on the underside).
- d) The centrifuge control panel is attached to the base internally with cable harnesses. Be careful not to stress the cables when removing the cabinet.
- e) Stand directly in front of the centrifuge and lift the cabinet straight up and off the base, setting it down on its right side.
- f) Gently remove the motor harness from the PCB.
- g) Gently remove the power supply harness from the PCB.
- h) Disconnect the PCB grounding strap from the base panel using a 11/32" nut driver.

6.7 Replacing the Lid Tray Assembly

- a) The lid tray assembly is accessible once the cabinet has been removed.
- b) The lid tray assembly is held in place with four screws.
- c) Peel the 'open/close' label off of the cabinet.
- d) Use a #2 Phillips screwdriver to remove the two lid tray screws concealed beneath the label.
- e) Gently remove the lid tray wire harness from the PCB.
- f) Use a #2 Phillips screwdriver to remove the two lid tray screws inside the cabinet
- g) To install the lid tray, reverse steps F through C above
- h) Complete the installation by gently plugging the lid tray wire harness into the PCB header 'J2'.

6.8 Replacing the PCB

- a) The PCB is accessible once the cabinet has been removed. Make certain that all wire harnesses have been disconnected.
- b) The PCB has capacitors that will remain charged for a period after the centrifuge is unplugged. Make certain to use standard precautions for handling potentially charged capacitors when working with the PCB.
- c) The PCB is held in place with nine #6 screws.
- d) Use a #2 screwdriver to remove the PCB screws. The screw on the lower left corner of the PCB also secures the grounding strap.
- e) To install the PCB, align the PCB with the mounting standoffs of the front panel.

- f) Use a #2 screwdriver to install the PCB screws. Ensure the grounding strap is installed at the lower left corner of the PCB.
- g) Important: over tightening the PCB screws can cause malfunction by stripping the screw threads away from the plastic mounting boss.

6.9 Replacing the Rotor

- a) The rotor is accessible once the cabinet has been removed.
- b) The rotor is held in place with the rotor screw and washer.
- c) Use a 1/8" hex driver to remove the center rotor screw and washer (turn counter-clockwise).
- d) Pull up on rotor to remove from guard bowl. Make sure the red rotor hub stays on the motor shaft.
- e) Place new rotor onto rotor hub and fully seat inside the guard bowl.
- f) Place washer onto center of rotor core and insert rotor screw. Use a 1/8" hex driver and tighten to 2.0 Nm.

6.10 Replacing the Motor

- a) Make certain that a new rubber gasket is used on the motor mounting studs when installing a motor.
- b) Position the motor assembly so its wires are adjacent to the notch in the bottom rim of the guard bowl.
- c) Install the motor and gasket into the guard bowl with the wire harness positioned as described above.
- d) Secure the motor to the guard bowl using four #8 washers and four #8 Nylok nuts.
- e) Drive the four #8 Nylok nuts onto the motor studs with an 11/32" nut driver.
- f) Turn the guard bowl assembly upside down.
- g) Place the base assembly onto the guard bowl.
- h) Ensure the motor wires pass through the notch in the bottom rim of the guard bowl.
- i) Ensure the guard bowl and base assembly are oriented such that the motor wires exit the guard bowl closest to the back left corner of the base assembly.
- j) **IMPORTANT: Make certain that no wires are pinched between the guard bowl and base!**
- k) Fasten the guard bowl to the base with six #8 thread cutting screws.
- l) Install the exhaust air cover with three #8 screws and washers.
- m) Secure the wire harnesses to the base assembly with zip ties.
- n) The lower assembly is complete.

6.11 Power Connections and Final Assembly

- a) Make certain that the lower assembly is unplugged from the external power supply.
- b) Connect the motor/power connector to J14 on the PCB.
- c) Connect the motor/hall sensor connector to J10 on the PCB.
- d) Connect the power supply harness connector to J17.
- e) Connect the grounding strap to the base assembly using a 11/16" nut driver.
- f) Carefully place the cabinet onto the base taking care not to pinch any wires between the two.
- g) Complete the assembly by replacing the nine screws and three washers using a #2 Phillips screwdriver.

7 ASSEMBLY DRAWINGS – Dash Apex 6 Centrifuge

7.1 FINAL CENTRIFUGE ASSEMBLY

7.1.1 Reference drawing 01-076-109-000

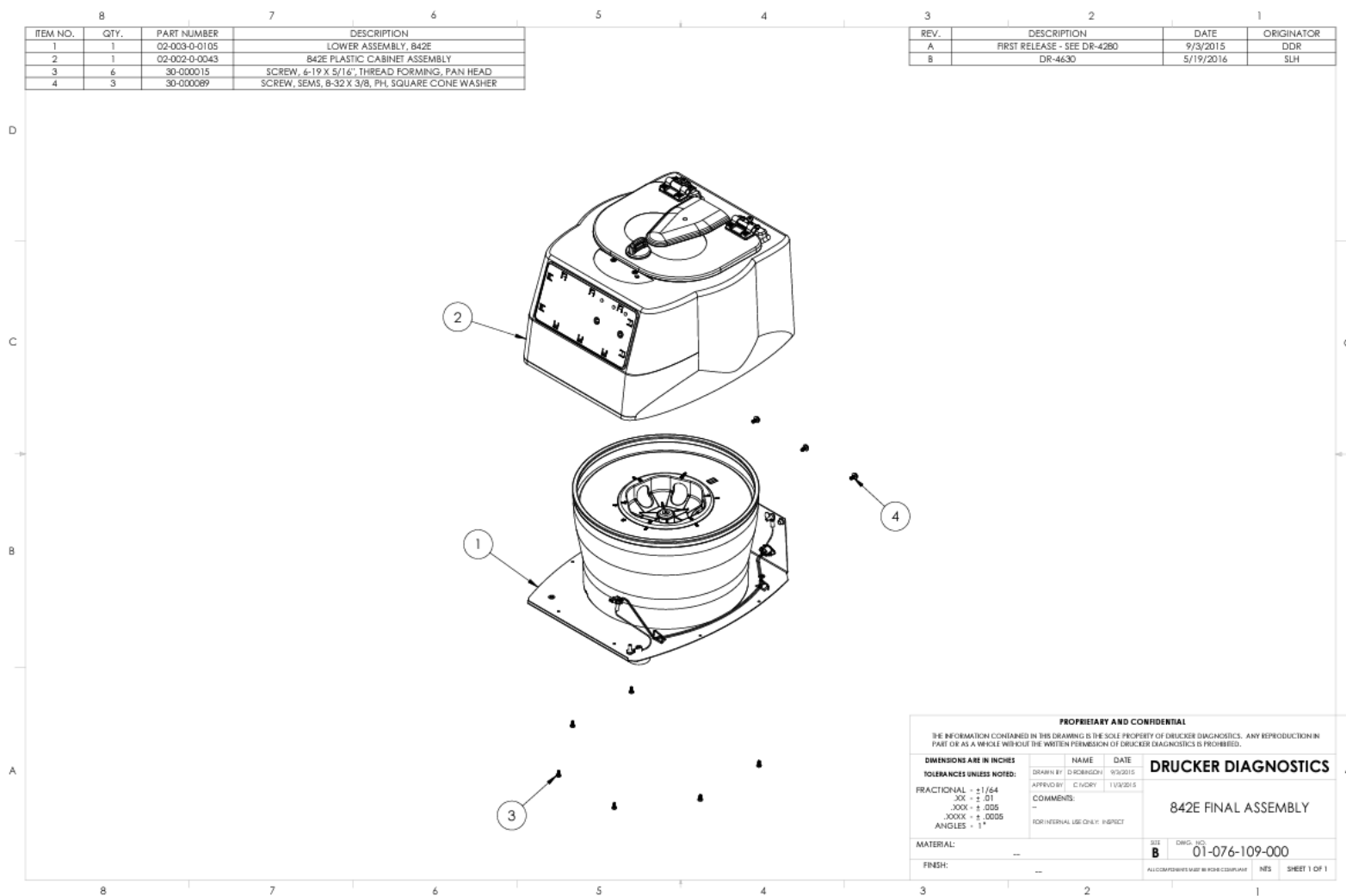

CABINET ASSEMBLY

7.1.2 Reference drawing 02-002-0-0043

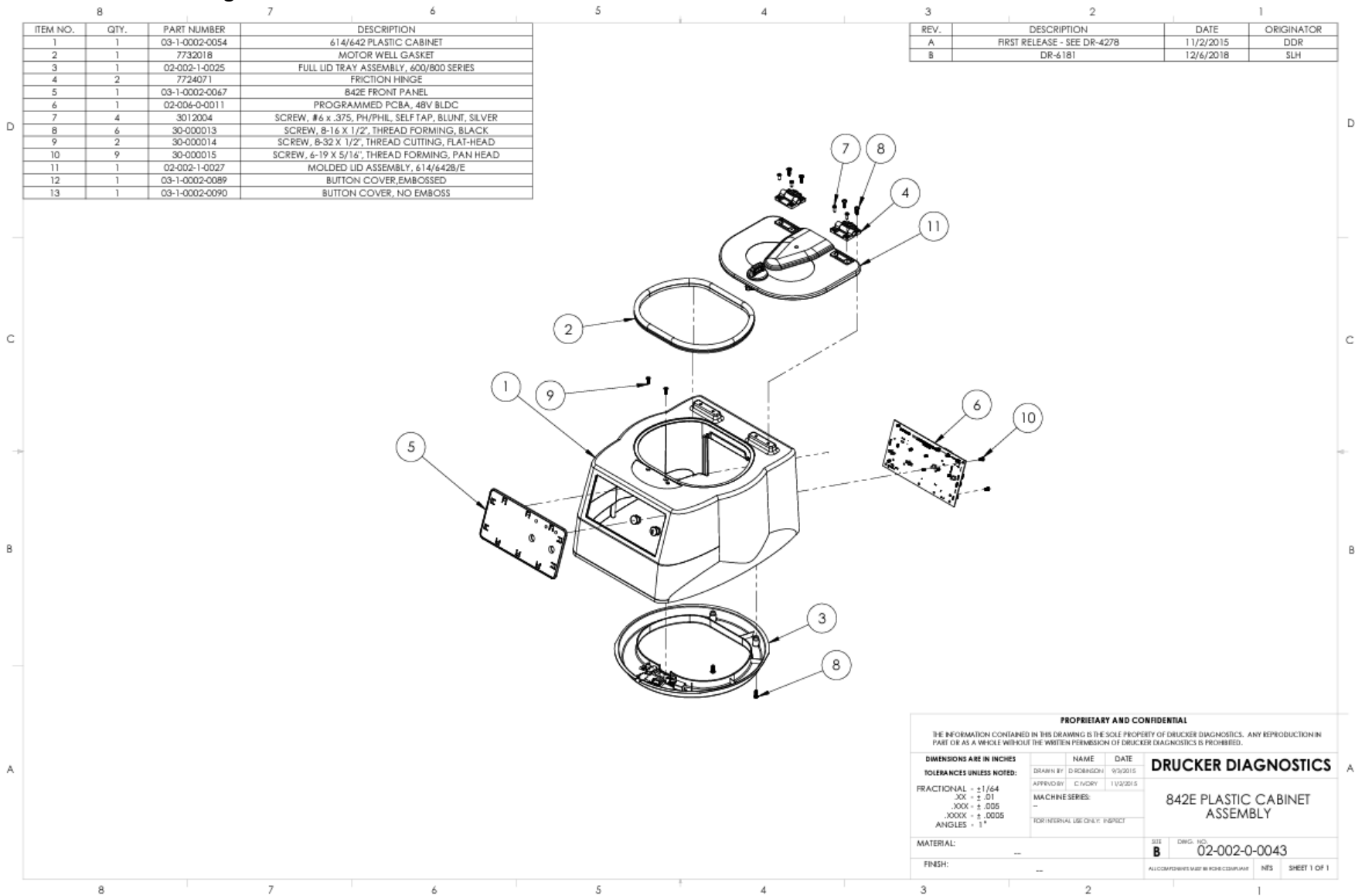

7.2 LOWER ASSEMBLY

7.2.1 Reference drawing 02-003-0-0105

ITEM NO.	QTY	PART NUMBER	DESCRIPTION
1	1	02-003-1-0039	DASH APEX 6 BASE ASSEMBLY
2	1	02-005-1-0010	MOTOR ASSEMBLY, DASH APEX 6
3	1	03-1-0004-0037	GUARD BOWL, MOLDED, 600 SERIES
4	1	03-1-0004-0036	GASKET, MOLDED GB
5	1	7713027	EXHAUST AIR DEFLECTOR
6	2	7730009	EXHAUST GASKET
7	1	02-001-0-0011	ROTOR ASSEMBLY, DASH APEX-6
8	1	30-000069	ROTOR WASHER
9	1	30-000060	PHCS, STAINLESS, BLACK OXIDE, 10-32 X 3/4"
10	1	3030002	TAPE, REFLECTIVE, RPM CHECK
11	3	3012007	SCREW, PHILLIPS, 8-32, 0.50 LONG
12	7	3033003	WASHER #8, FLAT, SILVER
13	6	30-00013	SCREW, 8-16 X 1/2", THREAD FORMING, BLACK
14	4	3022003	8/32 NYLOCK NUT
15	2	3033012	#8 INTERNAL TOOTH WASHER
16	2	3022001	NUT, HEX, 8-32
17	4	7746037	ø14/ø42 #8-32 SUCTION FOOT
18	2	3094002	TIE, PLASTIC, SELF LOCKING, 4.0"
19	2	30-000110	PHMG, 4-40 X 5/16", S5, BLACK
20	1	03-1-0005-0194	AC LINE FILTER, 250V, 3A
21	1	03-1-0005-0095	BRACKET, IPS, W/ INBERTS
22	2	30-000089	SCREW, SEMS, 8-32 X 3/8, PH, SQUARE CONE WASHER
23	1	03-1-0005-0192	INTERNAL POWER SUPPLY, 225W, 48V
24	4	30-000127	PHMG, S5, W/SPRNG WASHER, 4-40 X 1/4"
25	4	30-000128	NYLON PLASTIC WASHER, #4, .350 OD
26	1	03-1-0005-0223	APEX 6 POWER HARNESS (PI TO PCB A)
27	1	03-1-0005-0227	POWER HARNESS, AC INLET TO IPS
28	1	03-1-0005-0228	GROUND WIRE ASSEMBLY
29	1	03-1-0005-0246	POWER SWITCH, 10A
30	1	03-1-0005-0220	POWER HARNESS, AC INLET TO SWITCH
31	AJR	0000-099-172	LOCTITE 242
32	1	03-1-0010-0147	WARNING SYMBOL LABEL
33	2	7724002	GROUND LABEL

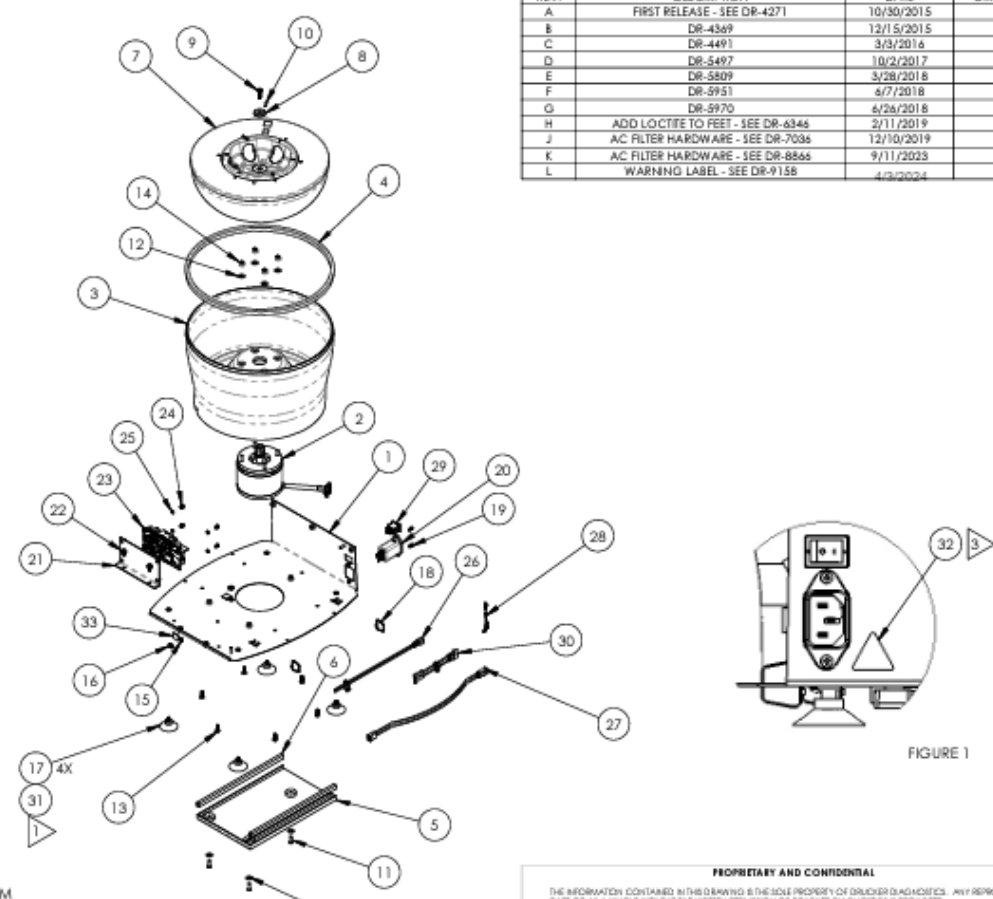

REV.	DESCRIPTION	DATE	ORIGINATOR
A	FIRST RELEASE - SEE DR-4271	10/30/2015	DDR
B	DR-4369	12/15/2015	DDR
C	DR-4491	3/3/2016	SLH
D	DR-3497	10/2/2017	SLH
E	DR-3809	3/28/2018	SLH
F	DR-5951	4/7/2018	SLH
G	DR-3970	6/26/2018	SLH
H	ADD LOCTITE TO FEET - SEE DR-6346	2/11/2019	SLH
J	AC FILTER HARDWARE - SEE DR-7036	12/10/2019	SLH
K	AC FILTER HARDWARE - SEE DR-8866	9/11/2023	SLH
L	WARNING LABEL - SEE DR-9158	4/2/2024	SLH

NOTES:

- FOLLOWING THE MANUFACTURER'S INSTRUCTIONS FOR USE, APPLY A MEDIUM STRENGTH THREAD LOCKER TO THE THREADS OF EACH SUCTION FOOT BEFORE ASSEMBLY.
- ASSEMBLE PER MP358
- APPLY WARNING LABEL (32) TO REAR OF BASE NEAR AC INLET AS SHOWN IN FIGURE 1

PROPRIETARY AND CONFIDENTIAL			
THE INFORMATION CONTAINED IN THIS DRAWING IS THE SOLE PROPERTY OF DRUCKER DIAGNOSTICS. ANY REPRODUCTION IN PART OR AS A WHOLE WITHOUT THE WRITTEN PERMISSION OF DRUCKER DIAGNOSTICS IS PROHIBITED.			
DIMENSIONS ARE IN INCHES	NAME	DATE	DRUCKER DIAGNOSTICS
TOLERANCES UNLESS NOTED:	DESIGN BY	APPROVED BY	
FRAC TIONAL - $\pm 1/64$	C. N. DRY	10/08/09	DASH APEX 6 LOWER ASSEMBLY
DEC - $\pm .01$			
ANGLES - 1°			
MATERIAL:	REV	DRWG. NO.	
FINISH:	B	02-003-0-0105	
		ALL DIMENSIONS UNLESS OTHERWISE SPECIFIED	ITS SHEET 1 OF 1

7.3 MOTOR ASSEMBLY

7.3.1 Reference drawing 02-005-1-0010

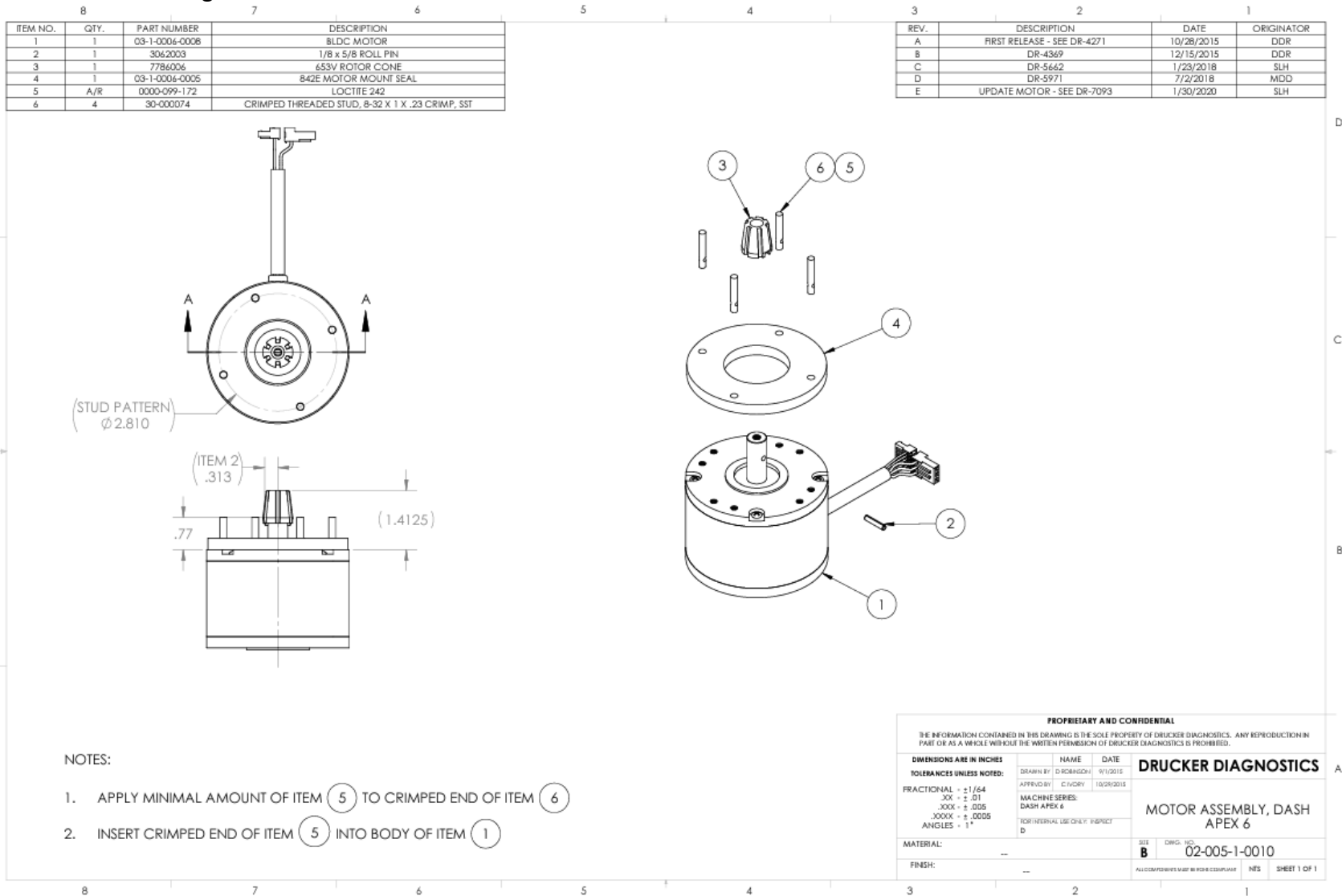

8 ASSEMBLY DRAWINGS – Dash Flex 6 Centrifuge

8.1 FINAL CENTRIFUGE ASSEMBLY

8.1.1 Reference drawing 01-176-109-000

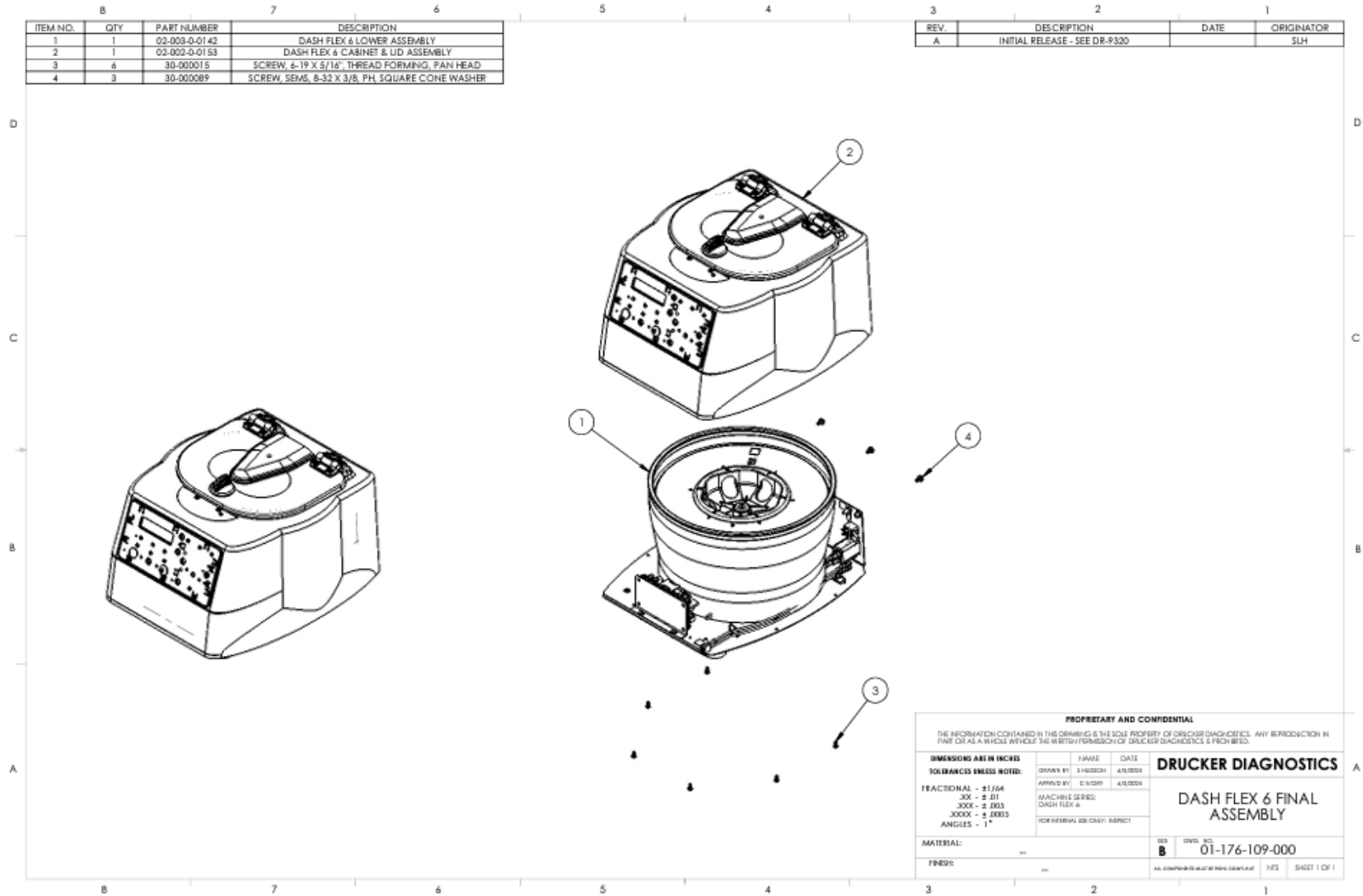

8.2 CABINET ASSEMBLY

8.2.1 Reference drawing 02-002-0-0153

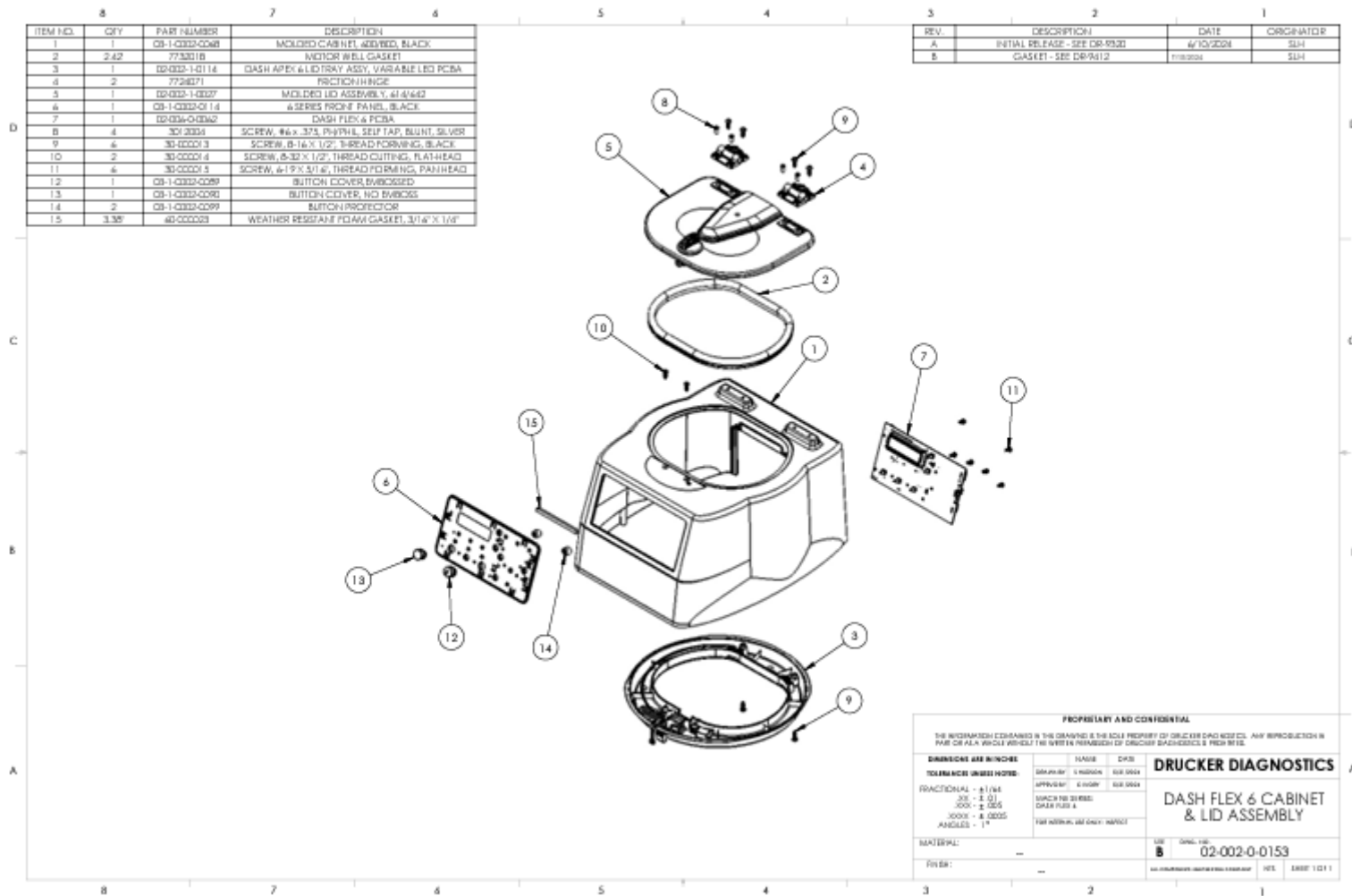

LOWER ASSEMBLY

8.2.2 Reference drawing 02-003-0-0142

ITEM NO.	QTY	PART NUMBER	DESCRIPTION
1	1	02-003-1-0039	DASH APEX 6 BASE ASSEMBLY
2	1	02-005-1-0020	DASH FLEX 6 MOTOR ASSEMBLY
3	1	03-1-0004-0037	GUARD BOWL, MOLDED, 600 SERIES
4	33.75*	03-1-0004-0036	GASKET, MOLDED G8
5	1	7713027	EXHAUST AIR DEFLECTOR
6	2	7732009	EXHAUST GASKET
7	1	02-001-0-0011	ROTOR ASSEMBLY, DASH APEX-6
8	1	30-000069	ROTOR WASHER
9	1	30-000080	FHCS, STAINLESS, BLACK OXIDE, 10-32 X 3/4"
10	1	3000002	TAPE, REFLECTIVE, RPM CHECK
11	3	3012007	SCREW, PHILLIPS, 8-32, D.50 LONG
12	7	3033003	WASHER #8, FLAT, SILVER
13	6	30-000013	SCREW, 8-16 X 1/2", THREAD FORMING, BLACK
14	4	3022003	8/32 NYLOCK NUT
15	2	3033012	#8 INTERNAL TOOTH WASHER
16	2	3022001	NUT, HEX, 8-32
17	4	7724037	614/642 #8-32 SUCTION FOOT
18	2	3094002	TIES, PLASTIC, SELF LOCKING, 4.0"
19	2	30-000110	PHMS, 4-40 X 5/16", SS, BLACK
20	1	03-1-0005-0194	AC LINE FILTER, 250V, 3A
21	1	03-1-0005-0246	POWER SWITCH, 10A
22	1	03-1-0002-0095	BRACKET, IPS, W/ INSERTS
23	2	30-000089	SCREW, SEMS, 8-32 X 3/8, PH, SQUARE CONE WASHER
24	1	03-1-0005-0192	INTERNAL POWER SUPPLY, 225W, 48V
25	4	30-000127	PHMS, SS, W/SPRING WASHER, 4-40 X 1/4"
26	4	30-000128	NYLON PLASTIC WASHER, #4, .250 OD
27	1	03-1-0005-0223	APEX 6 POWER HARNESS IPS TO PCBA
28	1	03-1-0005-0227	POWER HARNESS, AC INLET TO IPS
29	1	03-1-0005-0228	GROUND WIRE ASSEMBLY
30	1	03-1-0005-0220	POWER HARNESS, AC INLET TO SWITCH
31	A/R	0000-099-179	LOCTITE 242
32	1	03-1-0010-0147	WARNING SYMBOL LABEL
33	2	7724002	GROUND LABEL

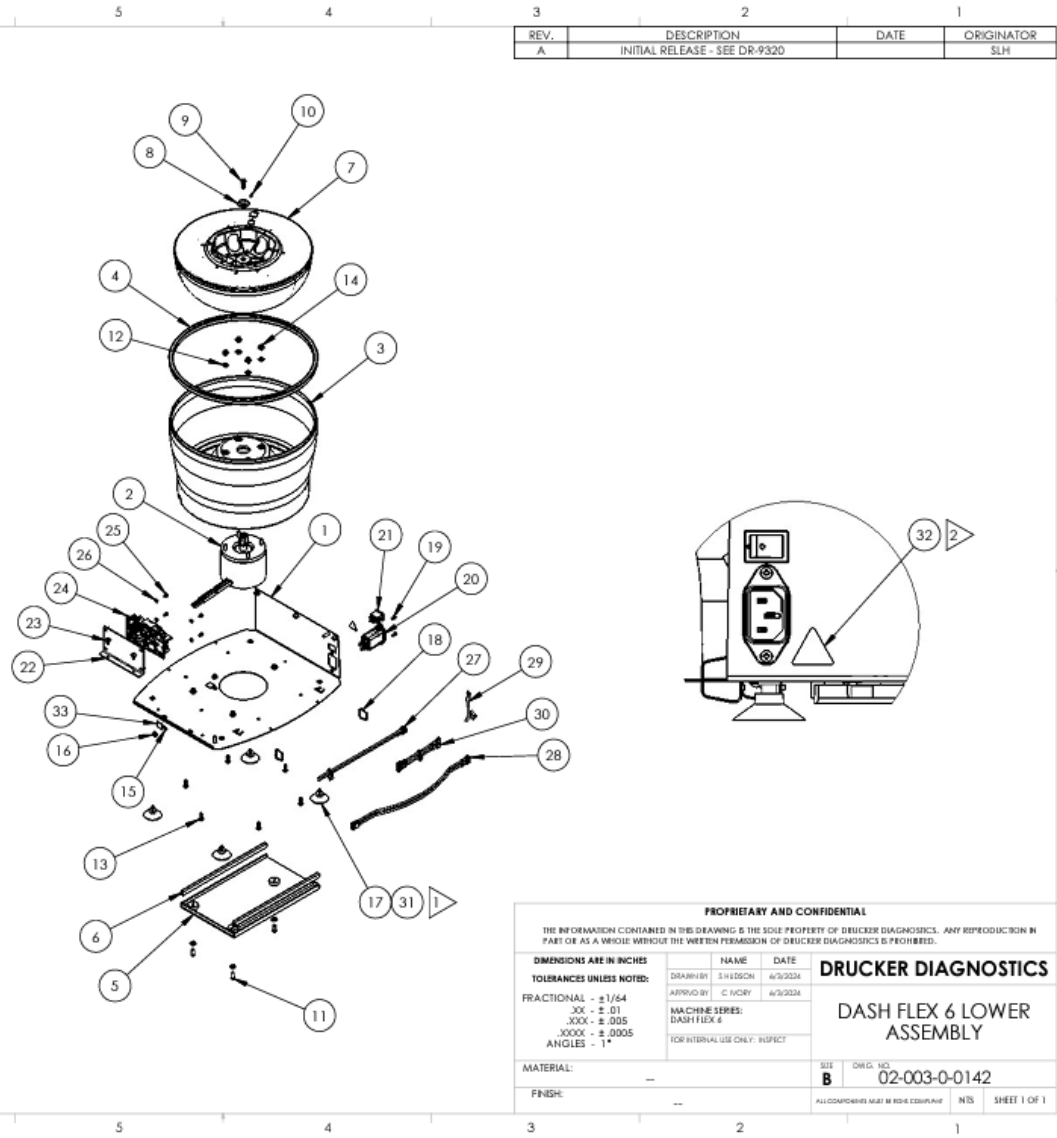

NOTES:

- 1 FOLLOWING THE MANUFACTURER'S INSTRUCTIONS FOR USE, APPLY A MEDIUM STRENGTH THREAD LOCKER TO THE THREADS OF EACH SUCTION FOOT BEFORE ASSEMBLY.
- 2 APPLY WARNING LABEL (32) TO REAR OF BASE NEAR AC INLET AS SHOWN

REV.	DESCRIPTION	DATE	ORIGINATOR
A	INITIAL RELEASE - SEE DR-9320		SLH

PROPRIETARY AND CONFIDENTIAL

THE INFORMATION CONTAINED IN THIS DRAWING IS THE SOLE PROPERTY OF DRUCKER DIAGNOSTICS. ANY REPRODUCTION IN PART OR AS A WHOLE WITHOUT THE WRITTEN PERMISSION OF DRUCKER DIAGNOSTICS IS PROHIBITED.

DRUCKER DIAGNOSTICS	
DASH FLEX 6 LOWER ASSEMBLY	
02-003-0-0142	

ALL DIMENSIONS MUST BE IN INCHES UNLESS OTHERWISE SPECIFIED

8.3 MOTOR ASSEMBLY

8.3.1 Reference drawing 02-005-1-0020

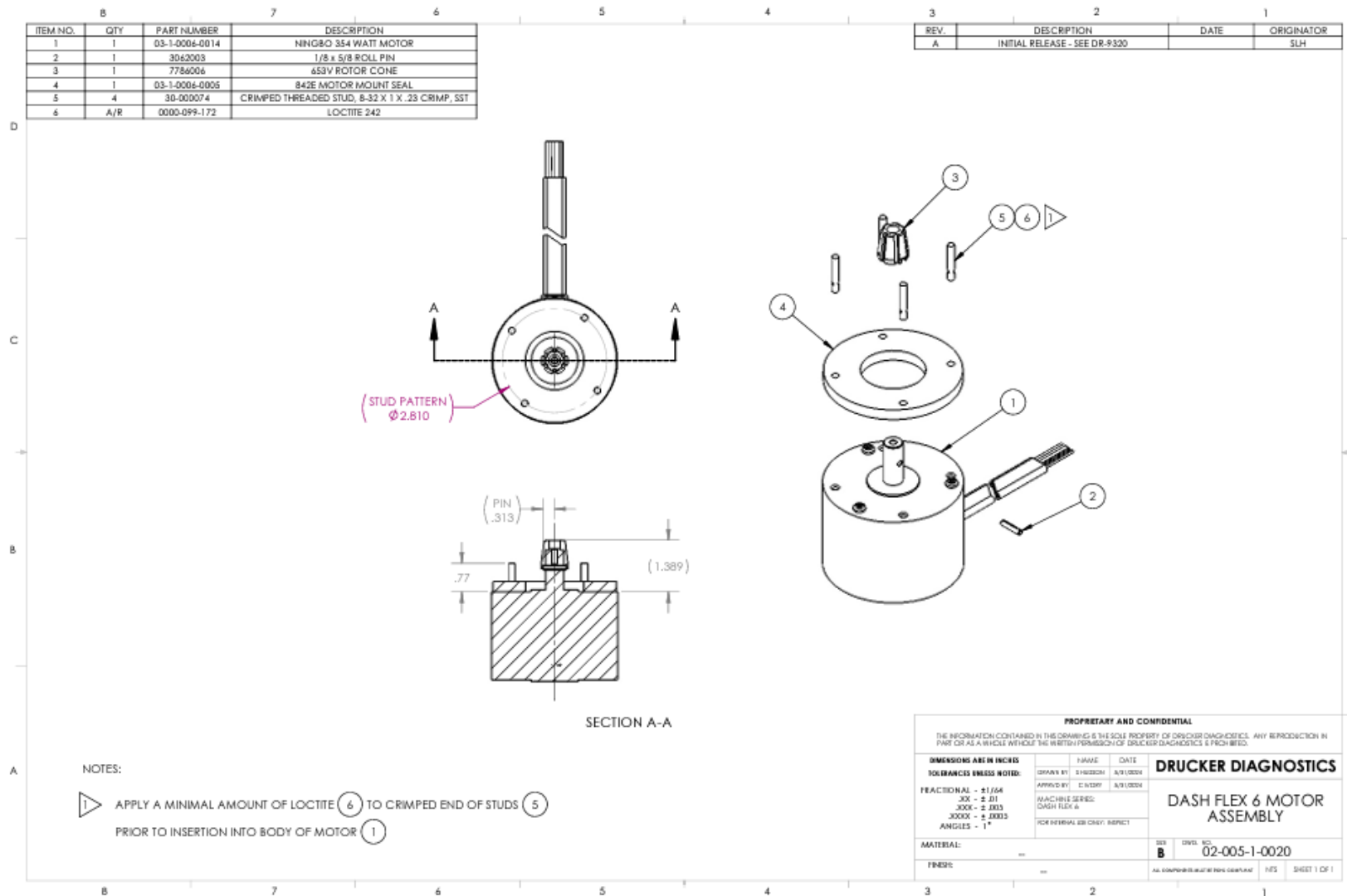

9 REVISION HISTORY

Revision #	Date	DR	Details of Change
A	11/17/2015	4324	Original Issue
B	7/11/2018	5998	Update torque specification and service instructions
C	7/25/2018	6309	Remove Intended Use Statement
D	8/13/2025	9475	Addition of the Dash Flex 6