



## Horizon Centrifuge Model 614B

A compact design for a compact budget

### OVERVIEW

The Model 614B is our most affordable fixed-angle centrifuge. Using advanced engineering materials and an advanced cooling system, the 614B provides high-quality fixed-angle separations for the physician's office or small lab.

### FEATURES

- **Mechanical Timer:** 1 min to 30 min allows for a range of applications
- **Fixed-Angle Rotor:** Fixed-Angle separations for up to six (6) tubes
- **Tube Sizes:** 0.5 mL to 15 mL; up to 17 mm x 125 mm
- **Brushless AC Motor:** Years of operation with no routine maintenance
- **Quiet Operation:** A double encased motor and the "stability mount" design provides excellent imbalance stability
- **Cool Operation:** Unique design of the convection based cooling system protects the samples even under the heaviest workloads
- **2 year warranty:** Peace of mind that parts, labor, and support are fully covered

### SAFETY

- **Safety Lid Switch:** Centrifuge will not operate with the lid open
- **Positive Lid Latching:** Firm mechanical latching of the lid prevents the escape of debris
- **Clear Shatter Proof Lid:** Allows for safe observation and optical calibrations
- **Reinforced Side Walls:** Glass fiber reinforced nylon & high-impact polycarbonate provide dual layers of safety protection.
- **Regulatory Approvals:** MET marked and certified to UL standard 61010A-1 & 61010A-2-20 and CAN /CSA C22.2 No. 1010.1 & C22.2 No. 1010.2.20

### APPLICATIONS

- **Blood Separations:** Chemistry, Coagulation, Serum Separators, and more
- **Urine Separations:** Urinalysis
- **General Purpose Use:** Other Clinical or Analytic Lab Applications



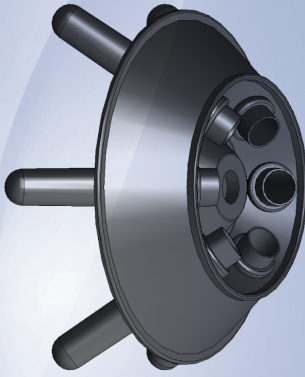

# 614B CENTRIFUGE ROTOR & ACCESSORIES



6 Place Fixed-Angel Rotor  
p/n 7786047

## Included with each centrifuge

	QTY Included	Part Number	Comments
	2	7713032	For use with 17 x 125 mm tubes
	6	7713031	For use with 17 x 100 mm tubes
	2	7713033	For use with 17 x 75 mm tubes

## Optional Accessories

	1" Cushion Spacer	Available as an accessory	1525	For use with glass vials or tubes
	Tube Holder Cap	Available as an accessory	7713011	For use when additional protection is desired