



QBC[®] Autoread Plus[™]

Centrifugal Hematology System

Operator's/Service Manual

For technical assistance in the United States, call:
1-866-265-1486

QBC, Autoread, Autoread Plus, and AccuTube are trademarks of QBC Diagnostics Inc., © 2006 QBC Diagnostics. Vacutainer is a trademark of Becton Dickson, Inc.

Section 1 – INTRODUCTION

1.1	INTENDED USE	1-1
1.2	SUMMARY OF TEST	1-1
1.3	PRINCIPLES OF THE PROCEDURE	1-2
1.4	WARNINGS AND PRECAUTIONS	1-2

Section 2 – INSTALLATION PROCEDURES

2.1	INSTALLATION SERVICE	2-1
2.2	AUTOREAD PLUS™ SYSTEM COMPONENTS	2-1
2.3	SETUP PROCEDURES	2-1
	2.3.1 Inserting Software Cartridge	2-1
	2.3.2 Electrical Connections	2-2
	2.3.3 QBC Capillary Centrifuge	2-2
	2.3.4 Power Requirements	2-3
2.4	INITIAL ADJUSTMENTS TO ANALYZER	2-4
	2.4.1 Display Contrast	2-4
	2.4.2 Selecting Display Language	2-4
	2.4.3 Setting Calendar Clock	2-5
	2.4.4 Setting Printout Format	2-6
2.5	SETTING BAUD Rate	2-7
2.6	CALIBRATION CHECK ROD	2-7
	2.6.1 Description	2-7
	2.6.2 Use	2-7

Section 3 – PRINCIPLES OF OPERATION

3.1	AUTOREAD PLUS ANALYZER	3-1
	3.1.1 General Description	3-1
	3.1.2 Display Panel	3-2
	3.1.3 Function Keys and Modes	3-2
	3.1.4 Transport Mechanism	3-3
	3.1.5 Optics	3-4
	3.1.6 Electronics	3-5
	3.1.7 Data Acquisition	3-6
	3.1.8 HDR Analysis Report	3-7
3.2	AUTOREAD PLUS POWER PACK	3-7
3.3	QBC CAPILLARY CENTRIFUGE	3-7
3.4	PRINTER	3-8
3.5	WORKSTATION ACCESSORY	3-8
3.6	VENOUS BLOOD PIPETTER	3-8
3.7	SPECIFICATIONS	3-8

Section 4 – OPERATING PROCEDURES

4.1	STARTING ANALYZER	4-1
	4.1.1 Power-On Self-Check	4-1
	4.1.2 Mode Selection	4-2
	4.1.3 Pre-Test Performance Check	4-2
4.2	HEMATOLOGY TESTS	4-2
	4.2.1 Selecting Patient’s Normal Range	4-3
	4.2.2 Starting an Assay	4-3
	4.2.3 Hematology Printouts	4-4
	4.2.4 Assaying Additional Tubes	4-5
4.3	TEST ALERTS	4-6
	4.3.1 Flashing Values and Dashes	4-6
	4.3.2 Special HB-MCHC Conditions	4-6
4.4	ERROR MESSAGES	4-7
4.5	SYSTEM CHECKS	4-7
	4.5.1 Calibration Check Rod	4-7
	4.5.2 QBC Controls	4-8
	4.5.3 QBC Proficiency Tests	4-9
4.6	OPTION FUNCTIONS	4-10
4.7	QBC CAPILLARY CENTRIFUGE	4-10
4.8	DIAGNOSTIC SCANS	4-11
4.9	QBC PIPETTER	4-14
4.10	PRECAUTIONS AND HAZARDS	4-15

Section 5 – SPECIMEN COLLECTION AND PREPARATION FOR TESTING

5.1	VENOUS BLOOD FOR HEMATOLOGY	5-1
	5.1.1 Collection Procedures	5-1
	5.1.2 Anticoagulants	5-1
	5.1.3 Interfering Substances — QBC AccuTubes™	5-1
	5.1.4 Specimen Storage and Stability — QBC AccuTubes	5-2
5.2	CAPILLARY BLOOD FOR HEMATOLOGY	5-2
	5.2.1 Collection Procedures	5-2
	5.2.2 Anticoagulants	5-2
	5.2.3 Interfering Substances	5-2
	5.2.4 Stability of QBC Capillary Tubes	5-2

Section 6 – TEST PROCEDURES

6.1	MATERIALS PROVIDED	6-1
6.2	MATERIALS REQUIRED BUT NOT PROVIDED	6-1
6.3	HEMATOLOGY TEST PROCEDURE WITH QBC ACCUTUBE	6-1
	6.3.1 Description	6-2
	6.3.2 Preparation and Handling of AccuTubes	6-2
6.4	BETWEEN-SPIN TIME DELAY FOR ACCUTUBES	6-5
6.5	FILLING ACCUTUBES WITH VENOUS BLOOD	6-5
6.6	ACCUTUBE QUALITY CONTROL	6-5
6.7	TROUBLESHOOTING TIPS FOR ACCUTUBES	6-6

Section 7 – SYSTEM PERFORMANCE

7.1	TEST RESULTS	7-1
	7.1.1 Digit-Decimal Format	7-1
	7.1.2 Operating Ranges	7-1
7.2	TEST LIMITATIONS	7-1
7.3	EXPECTED VALUES	7-2
7.4	SPECIFIC PERFORMANCE CHARACTERISTICS	7-2
	7.4.1 Precision	7-2
	7.4.2 Accuracy	7-4

Section 8 – BIBLIOGRAPHY 8-1

APPENDIX A-1 – TEST PROCEDURES FOR QBC VENOUS, AND CAPILLARY TUBES

A-1.1	MATERIALS PROVIDED	A-1-1
A-1.2	MATERIALS REQUIRED BUT NOT PROVIDED	A-1-1
	A-1.2.1 QBC Tubes for Hematology Test	A-1-1
A-1.3	HEMATOLOGY TEST PROCEDURES	A-1-1
	A-1.3.1 Procedures with QBC Venous Tubes	A-1-2
	A-1.3.2 Procedures with QBC Capillary Tubes	A-1-4
A-1.4	CALIBRATION DETAILS	A-1-10
A-1.5	QUALITY CONTROLS	A-1-10
	A-1.5.1 QBC Hematology Tests	A-1-10

APPENDIX A-2 – SYSTEM PERFORMANCE WITH QBC VENOUS, AND CAPILLARY TUBES

A-2.1	TEST RESULTS	A-2-1
	A-2.1.1 Digit-Decimal Format	A-2-1
	A-2.1.2 Operating Ranges	A-2-1
A-2.2	TEST LIMITATIONS	A-2-2
A-2.3	EXPECTED VALUES	A-2-2
A-2.4	SPECIFIC PERFORMANCE CHARACTERISTICS	A-2-3
	A-2.4.1 Precision	A-2-3
	A-2.4.2 Accuracy	A-2-4

APPENDIX B – SERVICE, MAINTENANCE AND SPECIFICATIONS

B.1	INTRODUCTION	B-1
B.2	SERVICE AND MAINTENANCE	B-1
	B.2.1 Autoread Plus Analyzer	B-1
	B.2.2 Power Pack	B-1
	B.2.3 QBC Capillary Centrifuge	B-1
	B.2.4 QBC Pipetter	B-1
B.3	SPECIFICATIONS	B-2
	B.3.1 Autoread Plus Analyzer	B-2
	B.3.2 Power Pack	B-2
	B.3.3 QBC Capillary Centrifuge	B-2

APPENDIX C – LIST OF PARTS, QBC AUTOREAD PLUS SYSTEM..... C-1

APPENDIX D – WARRANTY D-1

Section 1 Introduction

1.1 INTENDED USE

The QBC® Autoread Plus™ System (Figure 1-1) provides a 9-parameter hematology profile of centrifuged venous or capillary blood. The QBC Autoread Plus System provides a diagnostic hematology profile of the following quantitative values from a single tube of blood:

- Hematocrit
- Hemoglobin
- Mean Corpuscular Hemoglobin Concentration
- Platelet Count
- White Blood Cell Count
- Granulocyte Count (% and number)
- Lymphocyte-Monocyte Count (% and number)

The Autoread Plus System consists of the Autoread Plus analyzer with replaceable software cartridge and interconnecting power pack, a printer, the QBC Capillary Centrifuge, and various test accessories. Depending on the software version of the software cartridge, an analysis of test results is performed by a computerized reference program; the resulting printout provides a hematology diagnostic reminder (HDR report) on abnormal conditions for clinical follow-up by the physician.*

1.2 SUMMARY OF TEST

The methodology of the QBC test is based on electro-optical linear measurements of the discrete layers of packed blood cells in a microhematocrit-type tube (Figure 1-2). The cell layering results from density gradients formed during high speed centrifugation of the blood.¹⁻⁶ Nine primary hematology values including the platelet count are derived. A diagnostic report on abnormal parameters is provided, based on computer-stored hematologic data against which the test values are analyzed.* Tests are entirely automatic, requiring only that the operator prepare the sample tube and insert it into the instrument. Results, including the HDR report, take approximately 1½ minutes to obtain, depending on the software version.

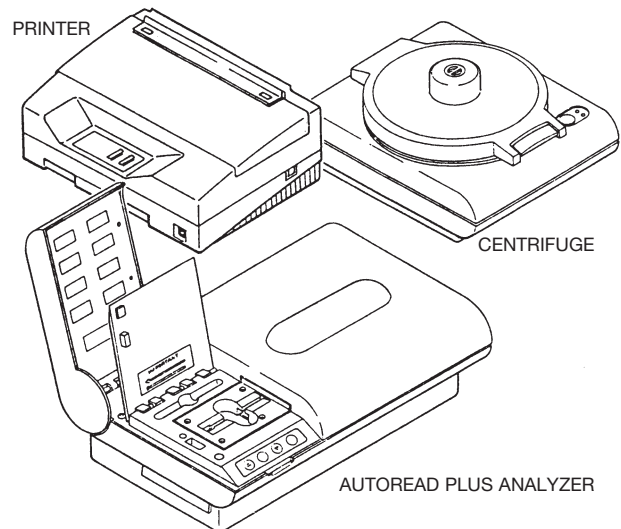

Figure 1-1.
QBC Autoread Plus Hematology System

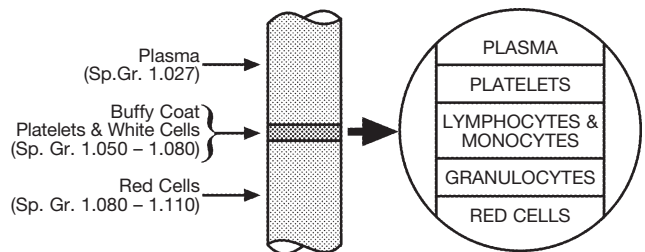

Figure 1-2.
Cell Layering in Spun Microhematocrit Tube

*Hematology diagnostic reminder (HDR) program not contained in all software versions.

1.3 PRINCIPLES OF THE PROCEDURE

QBC hematology tests utilize precision-bore glass tubes pre-coated with potassium oxalate, acridine orange fluorochrome stain,⁷ and an agglutinating agent. QBC tubes made specifically for capillary blood (finger-stick samples) additionally contain a coating of anti-coagulants. During high-speed centrifugation of the blood-filled tube, the cells form in packed layers around the float, which has descended into the buffy coat (Figure 1-3).⁸

The Autoread Plus analyzer accommodates all QBC tube types. The spun tube is inserted in the analyzer, where it is automatically scanned and fluorescence and absorbance readings are made to identify the expanded layers of differentiated cells. Volumes of these packed cell layers are then computed to obtain quantitative values of the following:

- Hematocrit
- Hemoglobin
- Mean Corpuscular Hemoglobin Concentration
- Platelet Count
- White Blood Cell Count
- Granulocyte Count (% and number)
- Lymphocyte-Monocyte Count (% and number)

Hemoglobin is computed from density factors that determine its cellular concentration. Mean corpuscular hemoglobin concentration is calculated electronically according to the equation: $MCHC = (HB \div HCT) \times 100$.

1.4 WARNINGS AND PRECAUTIONS

The QBC Autoread Plus Hematology System is intended for *in vitro* diagnostic use.

Carefully observe all warnings and precautions in this manual and on labeling of QBC tubes concerning the safe handling of blood and blood-derived products.

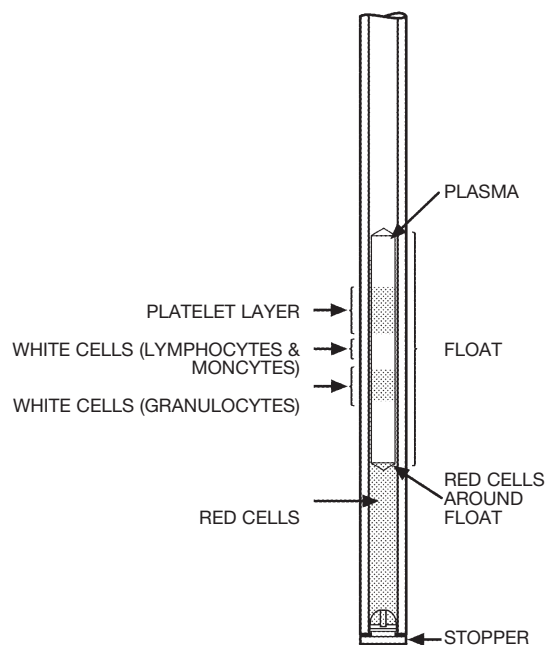

Figure 1-3.
Color-Separated Layers
Spun QBC Blood Tube

WARNING

Acridine orange reagent may be toxic; do not ingest. Avoid contact with skin, eyes, and clothing.

WARNING

Blood specimens may contain the Hepatitis B Virus (HBV), Hepatitis C Virus (HCV), Human Immunodeficiency Virus (HIV), or other disease-causing agents. Handle all patient specimens as potential biohazards capable of transmitting infection. Wear appropriate personal protective equipment, including gloves, when collecting and processing blood.

WARNING

QBC blood tubes are made of glass. Be careful when handling and preparing tubes to prevent breakage and possible injury. Inspect QBC tubes before use. Do not use cracked or scratched tubes.

Section 2 Installation Procedures

2.1 INSTALLATION SERVICE

The Autoread Plus System will normally be installed by a QBC Diagnostics Inc. representative. If necessary, contact your distributor or the nearest office of QBC Diagnostics Inc. to arrange for installation service.

2.2 AUTOREAD PLUS SYSTEM COMPONENTS

System Part No.	Analyzer Part No.	Power Pack Part No.	QBC Capillary Centrifuge Part No.
428605	429576	424590	425740

Test accessories included with the Autoread Plus System are:

- USB Printer (U.S. Only)
- USB Printer Cable
- Software Cartridge
- QBC Pipetter & AccuTube Spacer
- Small screwdriver for adjusting displays
- Calibration check rod
- Forceps for handling floats
- Workstation
- Operator's Manual (this document)

Test disposables for QBC hematology and optional accessories are listed in Appendix C.

2.3 SETUP PROCEDURES

2.3.1 Inserting Software Cartridge

(Note: For directions on installing software cartridges with USB compatibility, consult the included insert labeled "IMPORTANT INFORMATION".)

Install the software cartridge in the instrument prior to operation and while the Power switch of the unit is **Off**. Referring to Figure 2-1, orient the cartridge so that *the label faces up*; then insert the cartridge into the slot in the back panel. Push in firmly until the cartridge "finger" is mated to the circuit board connector.

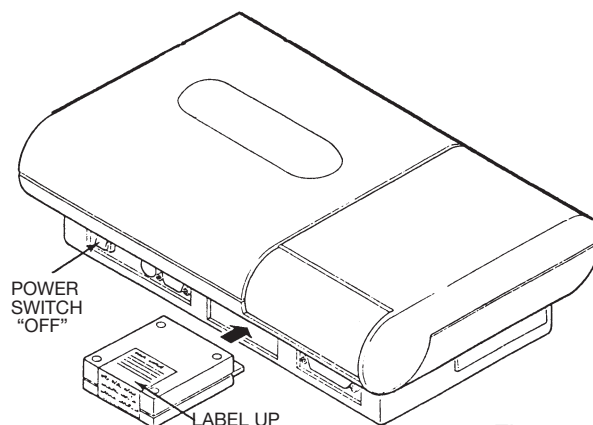

Figure 2-1.
Inserting Software Cartridge into Analyzer

CAUTION

Damage to electronic circuitry can occur if power is on while the cartridge is being inserted into or removed from the analyzer. Always be sure the power switch is off before installing or removing the cartridge.

2.3 SETUP PROCEDURES (continued)

2.3.2 Electrical Connections

- Analyzer-to-Power Pack

Referring to Figure 2-2, insert the 8-pin plug of the power pack into the POWER PACK CONNECTOR in the back of the Autoread Plus analyzer.

Before plugging the line cord of the power pack into an electrical receptacle, see the electrical requirements specified on the data plate and in Section 2.3.4.

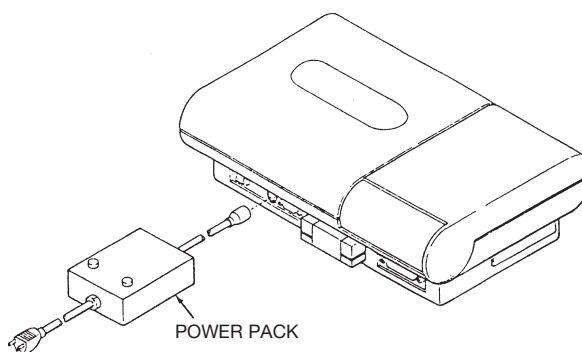

Figure 2-2.
Power Connection Diagram

- Analyzer-to-Printer

(Note: For analyzers with USB printers, consult the included insert labeled "IMPORTANT INFORMATION".)

In order to connect the printer, the cable assembly supplied with the System must be installed between the Autoread Plus analyzer output port and the printer. Referring to Figure 2-3, attach the cable as follows:

- Insert the 25-pin plug of the cable assembly into the PRINTER connector in the back panel of the analyzer.
- Secure the plug to the connector by manually tightening the knurled captive screws into the sockets of the connector. Note: the captive screws are slotted and can be tightened with a screwdriver.
- Plug the unattached connector of the cable into the jack on the printer.

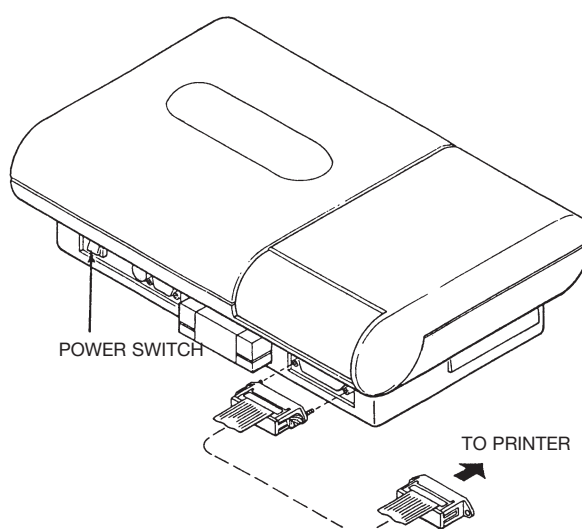

Figure 2-3.
Printer Cable Connection

See the manufacturer's manual furnished with the printer for instructions on attaching accessories.

2.3.3 QBC Capillary Centrifuge

Consult the separate manual supplied with the QBC Capillary Centrifuge for detailed setup instructions, power requirements, and operating directions.

2.3 SETUP PROCEDURES (continued)

2.3.4 Power Requirements

Plug the power cords of the power pack and centrifuge into the grounded electrical receptacles rated for the line voltage and frequency specified on their respective data plates. For centrifuge voltage tolerances, consult the operator's manual of the QBC Capillary Centrifuge supplied with the System.

For proper operation of the Autoread Plus analyzer, the power source must deliver voltages within the limits specified below.

Model No.	Voltage	Tolerance
424590	Autoread Plus	90-265 VAC
	Power Pack	50-60 Hz

If the line voltage is known to fluctuate outside the above tolerances, notify the installer; a special voltage regulator may be required.

The analyzer is electrically energized by the rocker-type POWER switch in the back of the unit (see Figure 2-3). The switch is labeled with two positions: [0] = Off and [1] = On. When power is on, a green LED Power indicator on the front display panel is illuminated.

CAUTION

Connect the power cord only to a 3-wire grounded receptacle delivering the voltage and frequency specified on the data plate of the power pack. Where only a 2-wire receptacle is available, have it replaced by a qualified individual and in accordance with all specified electrical codes. If an extension cord is required, use only a 3-wire grounded cord with the proper voltage rating.

2.4 INITIAL ADJUSTMENTS TO ANALYZER

2.4.1 Display Contrast

Turn power on and test the calibration check rod (see Section 2.6). Check for readability of the displays while room light is at its normal working level. If necessary, turn the upper CONTRAST adjustment (Figure 2-5) with the accessory screwdriver; *clockwise* darker, *counterclockwise* lighter.

Use the lower CONTRAST control to adjust the MESSAGES display.

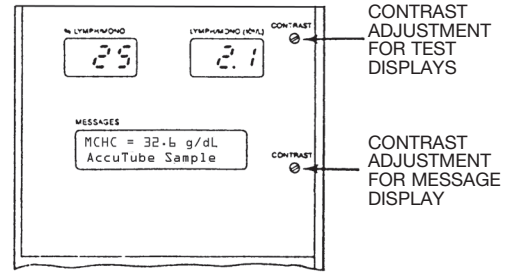

Figure 2-5.
Display Contrast Adjustments

2.4.2 Selecting Display Language

The procedures below describe how to select the desired display language with software cartridges that permit **multilanguage** displays.

Upon powering up for the first time (i.e., with a new cartridge), the display language will be *English*. To program a different display language with cartridges that contain multilanguage software, proceed as follows:

- First allow the analyzer to complete a Self-Check Sequence (see Section 4.1.1).
- Then press the [MODE] key until the OPTIONS MODE SELECT ▲ ▼ is obtained.
- Use the [▲] or [▼] keys to scroll through the following option functions:
 - Set Language
 - Set Units
 - Set Baud Rate
 - Cartridge Type
 - Set Print Format
 - Set Date & Time
- Press [NEXT] when the SET LANGUAGE option is displayed.
- Follow the SET LANGUAGE display and key sequence shown opposite to set the desired language.

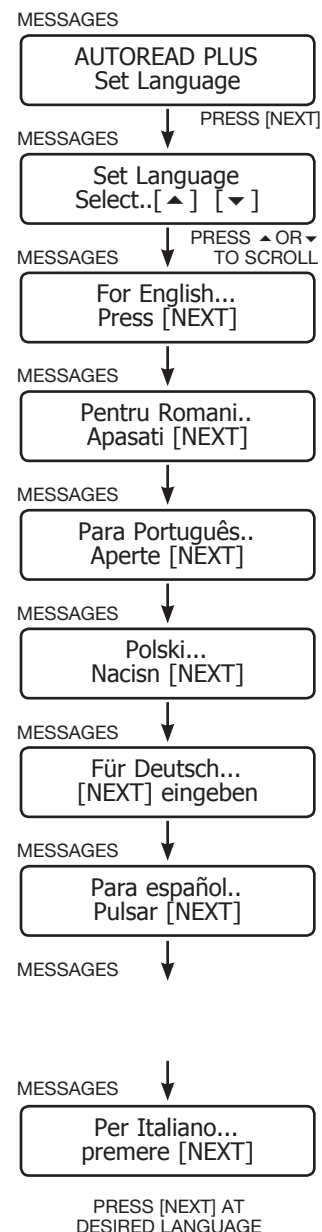

2.4 INITIAL ADJUSTMENTS TO ANALYZER

(continued)

2.4.3 Setting Calendar Clock

The Autoread Plus analyzer incorporates a battery-powered electronic clock that records the date and time on each printed test report. Whenever the Power switch is turned on, the analyzer is automatically sequenced through the start-up program described in Section 4.1. Upon satisfactory completion of the SYSTEM CHECK portion of start-up, the instrument momentarily displays the date and time currently set in the clock. Note: Depending on the programmed format of time – 12 or 24 hours – the date/time will appear as shown in one of the displays opposite.

If the date, time or hourly format require resetting, press the [MODE] key to advance the display to the OPTIONS MODE; then press the [▲] key to obtain the SET DATE & TIME option. Reset the clock to the correct date and local time by following the directions on the message displays opposite. At each step where indicated, use the [▲] or [▼] keys to adjust the numerical value to its correct setting; then press [NEXT] to advance to the next step.

To exit the clock setting option:

- Press [▲] or [▼] to select and set the test printout format (see 2.4.4),

or

- Press [MODE] to advance to the CBC MODE.

After initial re-setting of the clock, periodically check the date and time. If the date slips by one day, the clock battery is probably running low. (Note: estimated minimum service life of the battery is 10 years; **battery replacement, however, must be performed by an authorized service representative.**)

MESSAGES

9 August 1996
10:51

OR

MESSAGES

August 9, 1996
10:51 am

MESSAGES

OPTIONS MODE
Select... [▲] [▼]

PRESS [▲] KEY

MESSAGES

Autoread Plus
Set Date & Time

PRESS [NEXT]

MESSAGES

Time Format
12[▲] 24[▼]

(▲=12 HRS./▼=24 HRS.)
MESSAGES PRESS [NEXT]

Set Year
Year = 96

USE ▲ OR ▼
MESSAGES PRESS [NEXT]

Set Month
Month = 8

USE ▲ OR ▼
MESSAGES PRESS [NEXT]

Set Day
Day = 9

USE ▲ OR ▼
MESSAGES PRESS [NEXT]

Set Hour
Hour = 10

USE ▲ OR ▼
MESSAGES PRESS [NEXT]

Is it AM or PM ?
AM[▼] PM[▲]

USE ▲ OR ▼
MESSAGES PRESS [NEXT]

Set Minute
Minute = 51

USE ▲ OR ▼
MESSAGES PRESS [NEXT]

AUGUST 9, 1996
10:51 AM

PRESS [NEXT]

MESSAGES

Autoread Plus
Set Date & Time

(PRESS [MODE] TO EXIT)

2.4 INITIAL ADJUSTMENTS TO ANALYZER

(continued)

2.4.4 Setting Printout Format

When the QBC Autoread Plus analyzer is equipped with software that incorporates the Hematology Diagnostic Reminder or HDR program, the test printout format can be pre-selected from a menu of print options.

Using the [MODE] key, advance the display to the OPTIONS MODE (see opposite); access the SET PRINT FORMAT display by means of the [▲] or [▼] key, followed by the PRINTOUT OPTIONS display using the [NEXT] key.

Use the [▲] or [▼] key to preview the print options. Pre-program the analyzer to print out test results in one of three formats – or opt for no printout at all. Short vs Long HDR's differ in diagnostic detail, the Short form providing a summary or abbreviated report of the test result analyses. Press the [NEXT] key to enter the desired selection. Upon pressing [NEXT] to set the format, the operator will be given the choice of obtaining results on a printed page or label. After the page or label selection, the display will return automatically to the SET PRINT FORMAT. Exit by means of the [MODE] key.

The print format set here will be the format used to print out test results automatically after an assay is completed.

Note: The printout format can be temporarily changed after the completion of a test. See procedures in Section 4.2.3.

CAUTION

Be sure printer is approved for use and compatible with analyzer before connection to instrument.

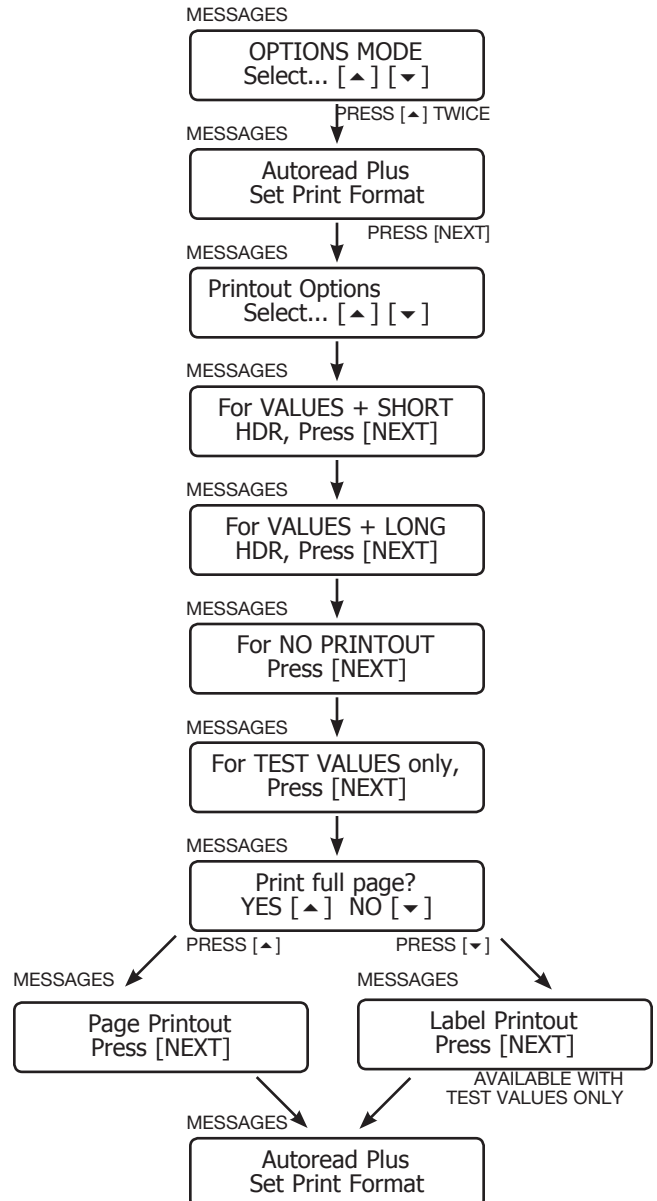

2.5 Setting Baud Rate

The analyzer is prepared for computer interfacing by first setting the baud or data transmission rate via the SET BAUD RATE option function. (See OPTIONS FUNCTIONS in Section 4.6.) Once this latter function has been entered, baud rates of 1200, 2400, 9600, 38,400, and 115,000 are selectable.

2.6 CALIBRATION CHECK ROD

2.6.1 Description

A calibration check rod is supplied with the system for daily performance verification of the Autoread Plus analyzer.

The calibration check rod (Figure 2-7) consists of a specially coded metal carrier rod. The carrier holds a plastic-coated label with an alternating pattern of black and fluorescent orange bars.

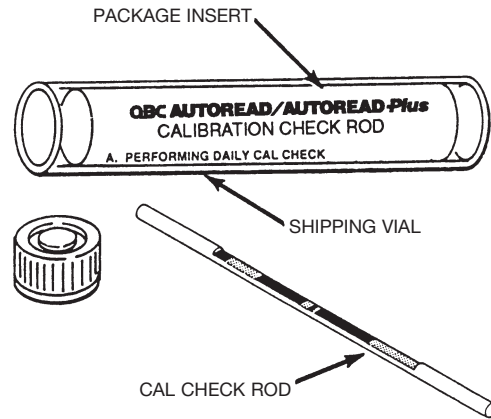

Figure 2-7.
Calibration Check Rod for Autoread Plus Analyzer

2.6.2 Use

The calibration check rod can be inserted in the analyzer in either direction, since the instrument automatically detects and adjusts for the reading direction.

As shown in the display opposite, a separate mode is provided for testing the calibration check rod. Upon installation and daily before assaying patient samples, the calibration check rod must be tested in order to verify satisfactory analyzer performance. Calibration check results are displayed on bargraph pictograms (see Figure 2-8) and immediately show whether the calibration test is acceptable.

Note: Daily testing with QBC Hematology Control and other quality assurance procedures are described in Section 4.5 of this manual.

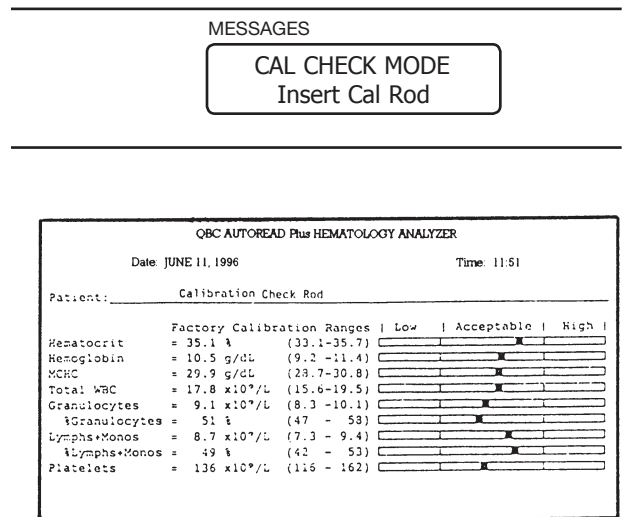
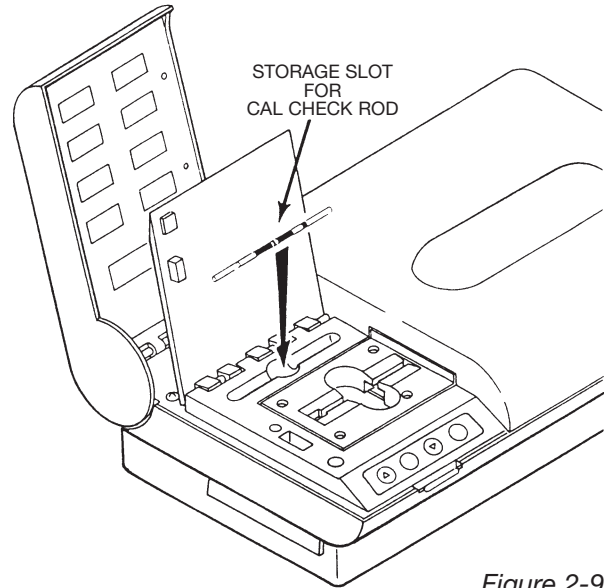

Figure 2-8.
Printout of Typical Calibration Check Rod Test

2.6.2 Use (continued)

As shown in Figure 2-9, a slot located directly behind the loading platform of the instrument is provided for storage of the calibration check rod.



*Figure 2-9.
Platform Door Opened
Showing Calibration Rod Storage Slot*

Section 3 Principles of Operation

3.1 AUTOREAD PLUS ANALYZER

3.1.1 General Description

The QBC Autoread Plus analyzer is a slim, compact instrument housed in a sturdy 4-piece enclosure (Figure 3-1).

Figure 3-2 shows the input/output connectors and controls located on the back of the instrument. The analyzer has no voltage- or frequency-dependent circuitry and operates on direct current voltages supplied from a separate power pack.

The hinged display of the unit (Figure 3-3) permits viewing of results, as well as access to the function keys and tube-loading platform. A QBC tube is inserted by opening the hinged platform door and placing the tube into the slotted platform, *open end facing right* toward the optics chamber. The door is then closed to initiate the test measurement. The ensuing procedure is automatic, requiring no operator involvement.

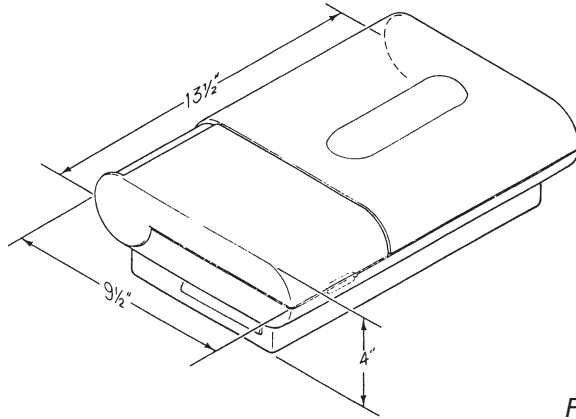

Figure 3-1.
Autoread Plus Analyzer (Storage Condition)

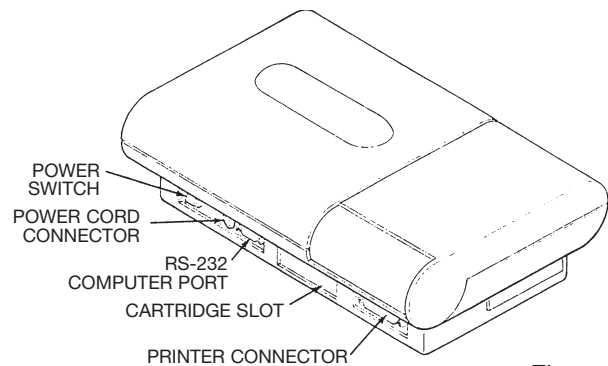

Figure 3-2.
Rear Panel Connector and Controls

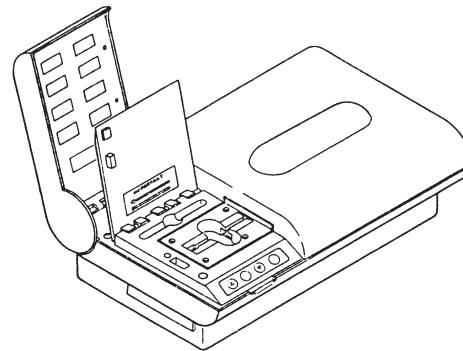

Figure 3-3.
Display Panel, Loading Platform and Keys

3.1.2 Display Panel

Readouts and controls on the display panel (Figure 3-4) are as follows:

- POWER light: Green LED, illuminated when rear POWER switch is On.
- Eight 3-digit windows with reflective type LCDs and fixed decimals.
- Upper CONTRAST adjustment for test readouts.
- MESSAGES display: two 16-character lines for alphanumeric messages.
- Lower CONTRAST adjustment for the readout.

When a test is completed, the results are displayed in the eight labeled windows, with the MCHC parameter displayed simultaneously on the first line of the MESSAGES readout; the type of QBC tube – AccuTube, venous, or capillary – is displayed on the second line of the readout.

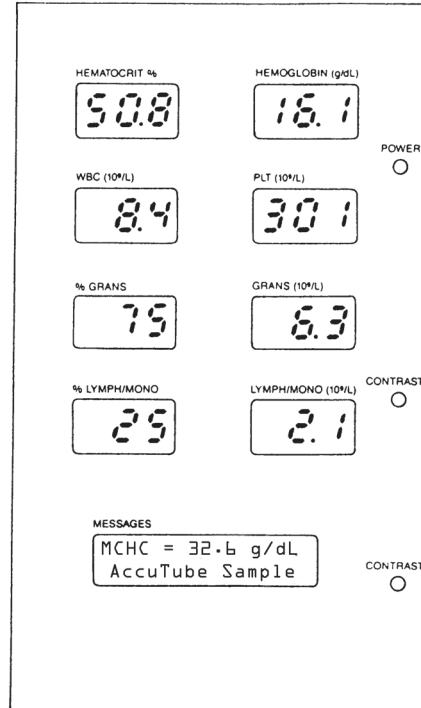

Figure 3-4.
Display Panel with Typical Results

3.1.3 Function Keys and Modes

The four function keys located in front of the loading platform (Figure 3-5) are tactile-type switches with embossed circular faces. Key functions are described below.

- [MODE] key: accesses the testing programs and non-testing options.
- [NEXT] key: to access the printing function and initiate a reprint; to perform various routines as defined by the displayed message; and to advance the current display.
- [▲] key: increases program numbers in setting date, time, etc. Also performs other functions defined by message routines.
- [▼] key: decreases program numbers. Also performs other functions as defined by message routines.

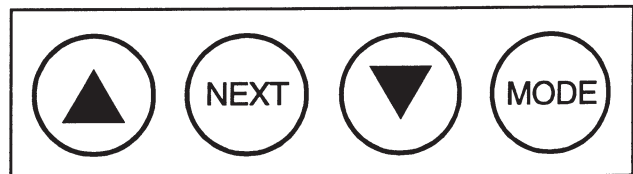

Figure 3-5.
Four-Switch Keyboard Pad

3.1.3 Function Keys and Modes (continued)

There are four main operating modes, three of which are for testing; and the fourth, for selecting options (see displays opposite).

Once programmed to a test mode, the instrument automatically determines the correct algorithms and processing routines from the optical characteristics (signature) of the inserted tube.

IMPORTANT: Before patient hematology tests, the operator can program a sex-specific adult normal range or pediatric normal range from a menu of 12 range selections. If the operator fails to select a specific normal range, test results will appear on bar graphs showing adult male and female normal ranges.

The OPTIONS MODE is for previewing the display languages, setting the calendar clock and print format and identifying the installed software cartridge. The baud rate option function is for computer interfacing.

3.1.4 Transport Mechanism

The tube loading platform (Figure 3-6) is designed so that an inserted tube will roll unaided into a slot and down into the transport carriage. Subsequently, the tube is colleted or clamped in the carriage.

The transport mechanism (Figure 3-7) consists of a metal carriage supported by a lead screw and guide rod and driven by a stepper motor. The motor is capable of a linear resolution of 0.000625 inches per step. In conjunction with the fluorodetector system, the transport unit functions as a precision optical micrometer.

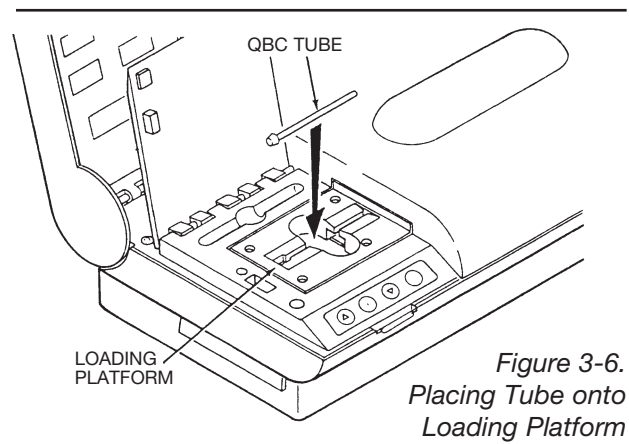
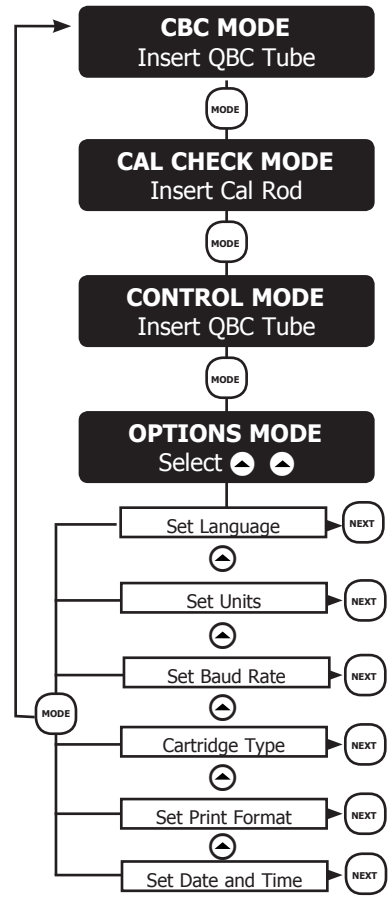

Figure 3-6. Placing Tube onto Loading Platform

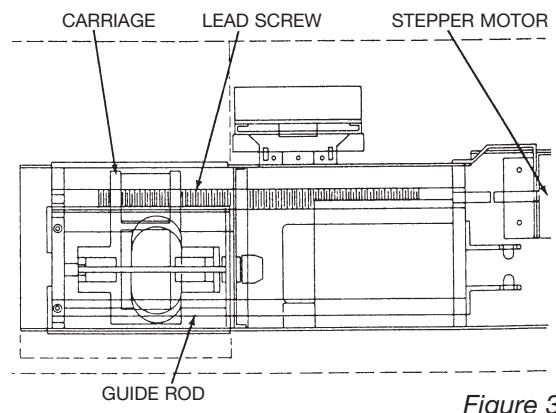

Figure 3-7. Transport Mechanism

3.1.4 Transport Mechanism (continued)

Inserting a QBC tube and closing the platform door initiates the following start sequence:

- An optical sensor detects that the tube is inserted, thereby activating a switch.
- As the door is shut, an actuating bar on the underside of the door closes a mechanical switch to enable the transport start sequence.
- A motor moves the transport carriage with collet to clamp the unsealed end of the tube firmly in position.
- Once the tube is colleted, the transport carriage moves away from the loading platform into the optics chamber.

The test sequence for a patient specimen consists of three phases:

- Identification scanning;
- Measurement scanning; and
- Data analysis.

Initially, the tube is subjected to forward and reverse check scans while the optical sensors determine the type of QBC tube float dimensions and plasma volume. (NOTE: Every scan – regardless of the test mode – is accompanied by a *muted whirring* sound caused by rapid acceleration of the motor and tube transport mechanism; this whirring sound is normal.) The tube then undergoes a series of rapid measurement scans as described in paragraph 3.1.7. When scanning is complete, the specimen tube is returned to the loading platform while the analysis and data reduction phase continues. Total test time is between 1 and 3 minutes depending on the software version and the test being performed.

The transport mechanism, lead screw, and guide rod are lubricated for the life of the instrument.

Should breakage ever occur during tube insertion or colleting, a removable waste tray below the loading platform is provided to collect specimen and glass (Figure 3-8).

3.1.5 Optics

The optics system, shown schematically in Figure 3-9, consists of three basic sections:

- Red light source, for transmittance scans.
- Blue light source, for fluorescence scans.
- Photodetector with associated focusing lens and filters.

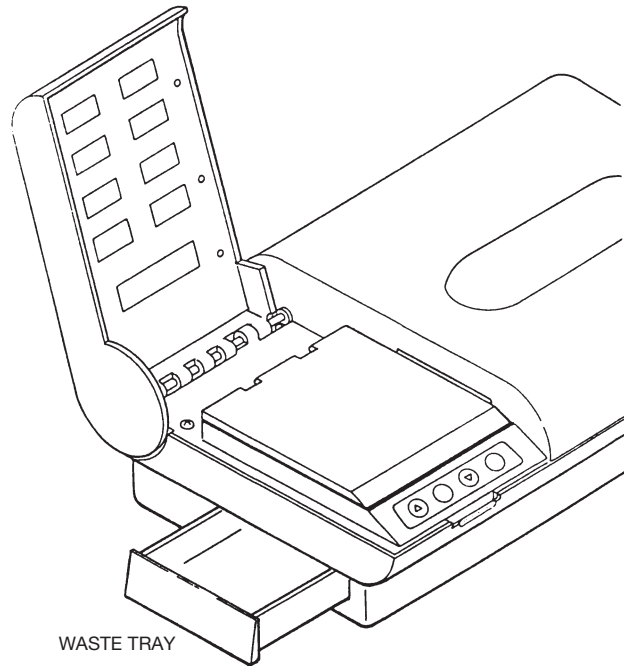

Figure 3-8.
Waste Tray Shown Partially Open

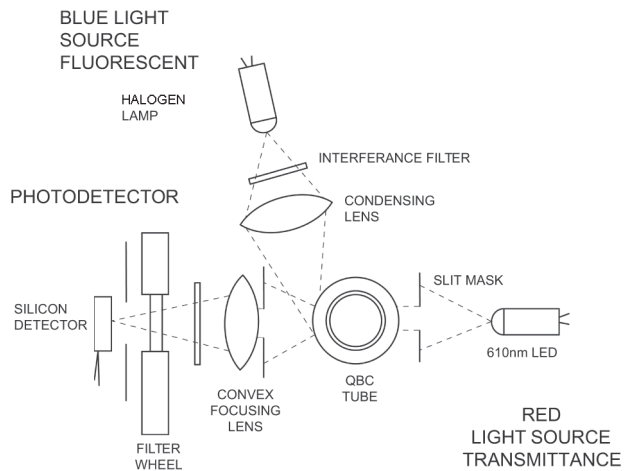

Figure 3-9.
Optics System Schematic

3.1.5 Optics (continued)

The red light source is a 610 nm LED and is used primarily for scanning the red cell layers in the blood tube and for detecting tube characteristics, i.e., closure type, tube type, fill volume, float length, etc. A slit mask controls the area of illumination of the tube.

The blue light source is a miniature tungsten lamp for fluorescence scanning of the buffy coat. An interference filter is used for blocking all light of a wavelength of 490 nm or longer. An aspheric condensing lens, having a focal length of 8.5 mm, concentrates the light energy onto the tube.

In order to maintain a constant relative position with respect to the photodetector, the blue light source is mechanically attached to the analyzer frame. The tube, which moves along its longitudinal axis, remains vertically perpendicular to the light source during the scanning process. The light source is movable for adjustment purposes only. A position layout of the optics chamber is shown in Figure 3-10.

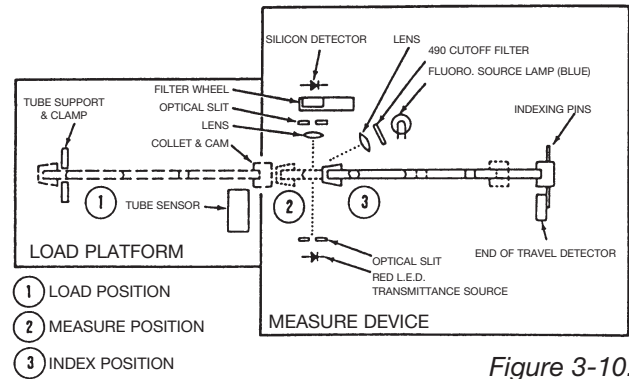

Figure 3-10.
Position Layout of Analyzer Optics

3.1.6 Electronics

The electronics of the analyzer (Figure 3-11) consists of a single chip microcomputer, allocated by function to the following four circuit boards:

- Main PC board, mounted in base of lower housing.
- Memory PC board, located in removable cartridge, with up to 512K bytes of UV-erasable program (EPROM).
- Display PC board.
- Optics PC board, photodetector pre-amplifier, and circuitry within shielded enclosure behind filter wheel housing.

The main PC board provides all of the instrument control functions, including the filter wheel and transport motor controls, illumination control, printer outputs, timekeeping, data storage, signal conditioning, and digitizing.

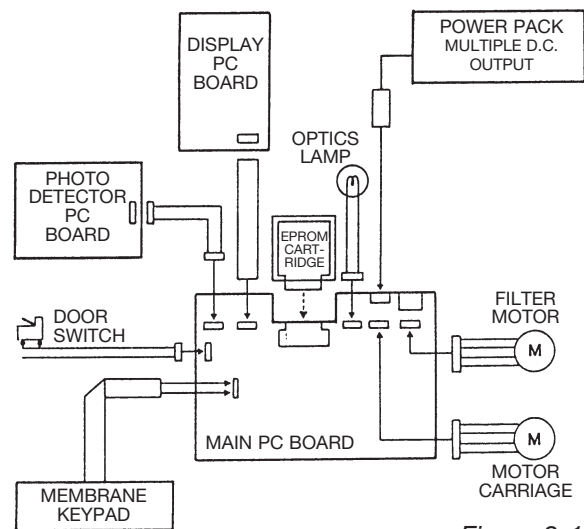

Figure 3-11.
Simplified Interconnection Diagram

3.1.7 Data Acquisition

Test data is read via a 12-bit analog-to-digital converter. A typical tube assay consists of the following:

- Forward and reverse transmittance and fluorescence scans of entire tube to determine tube type, float length, fill volume, etc.
- One fluorescence scan of float region in forward direction, with red filter in place.
- One fluorescence scan of float region in reverse direction, with green filter in place.
- Tube is indexed 45° axially in carriage, and fluorescence scans of b and c are repeated.

The above process is then repeated until *eight sets* of fluorescence scans are made around the circumference of the tube and float.

The microprocessor computes packed cell volumes (and resulting test values) from linear measurements of the color-differentiated packed cell layers shown in Figure 3-12. QBC tube parameters are thus a function of the following lengths:

- Hematocrit: L_1
- WBC: L_3 and L_4
- GRANS: L_3
- LYMPH/MONO: L_4
- Platelet Count: L_5
- Hemoglobin: Derived from $L_1, L_2, L_3, L_4,$ and L_5

The L_6 plasma column is also measured to determine the actual fill volume, which is between 65-75 μL for a QBC AccuTube. Data processing incorporates various digital filter, pattern recognition, and data conversion algorithms. The latter computations are based on the fact that each QBC tube exhibits a characteristic *signature* that must fall within prescribed tolerances.

Bandlength data from the eight pairs of scans made around the blood tube are analyzed and processed. Test readings are displayed only when data analysis confirms valid bandlengths in at least four sets of scanning measurements.

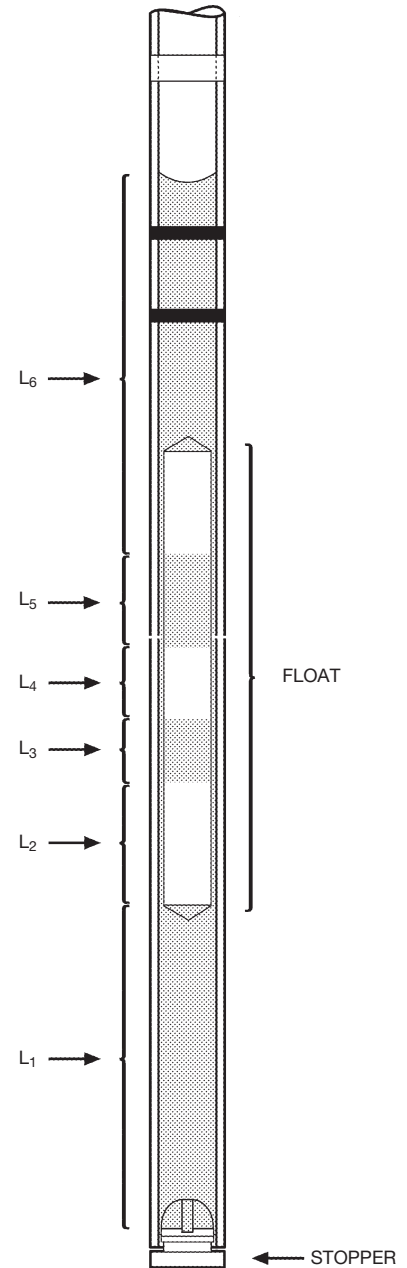

Figure 3-12.
Packed Cell Layers in QBC AccuTube

3.1.8 HDR Analysis Report*

The microprocessor, via the cartridge memory bank, contains an extensive database of medical diagnoses against which each nine-parameter test result is analyzed. The test printout will include a hematology diagnostic reminder or HDR report on general and specific clinical aspects relating to any abnormal values. Wintrobe's *Clinical Hematology*, 8th edition,¹ is referenced throughout the printed HDR report. **See the Caution note opposite on proper utilization of HDR report.**

Abbreviated (Short) or detailed (Long) analysis reports can be obtained. See Section 2.4.4 on programming HDR report printouts.

*Not provided in all cartridges.

3.2 AUTOREAD PLUS POWER PACK

The power pack supplies direct current (d.c.) voltages to the Autoread Plus analyzer. The power pack incorporates a conventional flyback switching design with four individually regulated d.c. outputs, as shown in Figure 3-13.

The Power switch on the analyzer controls and cuts the +20V and +12.5V supplies, the $\pm 16.5V$ supply being switched off electronically by cutting the 12.5V supply to the logic circuits.

3.3 QBC CAPILLARY CENTRIFUGE

The QBC Capillary Centrifuge (Figure 3-14) is a low-noise, high-speed instrument specifically designed to meet the cell packing requirements of the QBC test method.

Up to 20 blood tubes can be spun simultaneously. Nominal speed is 12,000 rpm and relative centrifugal force is approximately $14,387\times g$. Spin time is fixed at 5 minutes. For a detailed description of the QBC Capillary Centrifuge including setup and operating instructions see the operator's manual shipped with the instrument.

Since the QBC test method depends on proper cell layering of blood, the sample tubes must be protected from excessive heat in the centrifuge rotor compartment, which may adversely affect cell layer formation. Accordingly, be sure to wait between successive spins for the correct time specified in the applicable QBC Capillary Centrifuge manual.

CAUTION

A clinical diagnosis is a conclusion based on science and art that necessitates the full integration of the results of a detailed medical history, a careful physical examination and appropriate laboratory testing, together with the training, experience, and professional judgment of the treating physician. The statements derived by the HDR program are suggestions based upon a limited examination of only a part of a patient's hematologic status. HDR reminders have value only to a clinician who is able to use them as part of the complete diagnostic process.

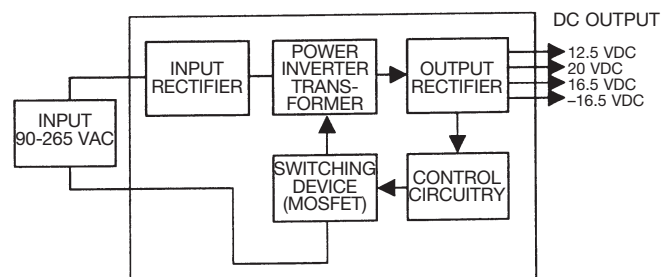

Figure 3-13.
Power Pack Outputs

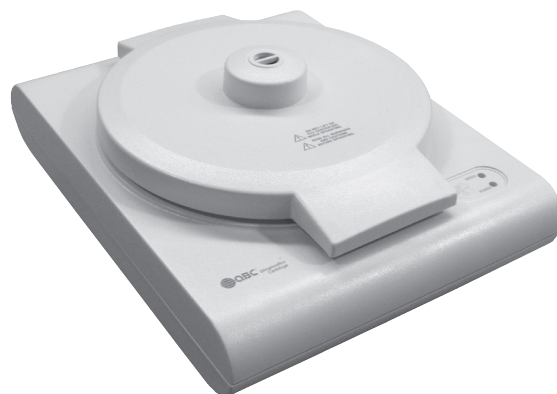

Figure 3-14.
QBC Capillary Centrifuge (p/n 425740)

3.4 PRINTER

For U.S. customers, a printer is supplied with the Autoread Plus System. For international customers, a printer with the correct voltage rating must be procured locally. *(Note: For additional information on working with USB printers, consult the included insert labeled "IMPORTANT INFORMATION".)*

Detailed directions on unpacking, set up, and operation of the printer are provided in the manufacturer's manual supplied with the unit.

3.5 WORKSTATION ACCESSORY

The QBC workstation (Figure 3-16), p/n 424226, is a convenient accessory to facilitate the preparation and storage of blood collection and centrifuged QBC tubes. The workstation incorporates a receptacle for the QBC venous blood pipetter, differently sized tube wells, and a notched and numbered front rack for centrifuged QBC tubes.

3.6 VENOUS BLOOD PIPETTER

The semi-automatic QBC pipetter shown in Figure 3-16 is a dedicated device for filling QBC tubes from a Vacutainer™ brand or similar blood collection tube. Fill volume is fixed at 111.1 μL for filling standard or venous blood tubes with specimen. An AccuTube spacer must be added to the pipetter to adjust the fill volume to 70 μL when filling QBC AccuTubes. Instructions for use are provided in Section 4.8.

3.7 SPECIFICATIONS

See Appendix B for specifications on the QBC Autoread Plus System.

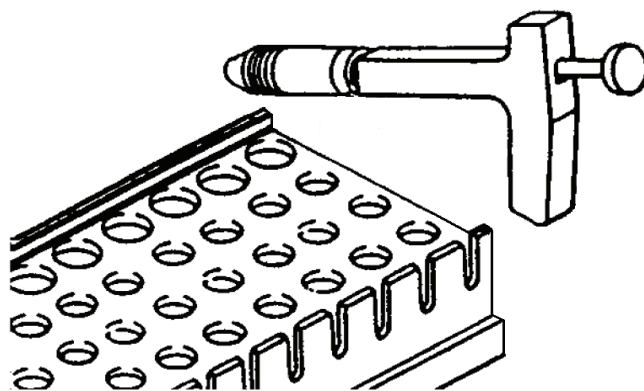

Figure 3-16.
QBC Workstation and Venous Blood Pipetter

Section 4 Operating Procedures

4.1 STARTING ANALYZER

4.1.1 Power-On Self-Check

Actuating the POWER switch on the back of the analyzer causes the instrument to test its internal electronics, optics, and mechanical systems, including the segmented LCD displays. **NOTE: Before turning power on, be sure the loading platform is empty (tube removed) and the platform door is closed.** If the door is left open, the self-check sequence will stop, and a display message to close the door will appear.

During the LCD display check (Figure 4-1), verify that all segments in all the numeral "8"s are illuminated and that decimal points are present in all readouts except %GRANS, %LYMPH/MONO, and PLT. Request service in the event of a defective display.

Status messages are automatically displayed during the startup sequence, as shown opposite.

If the SYSTEM CHECK phase fails, an alert message will appear that flags an error condition. See Table 4-3 for a list of startup error flags.

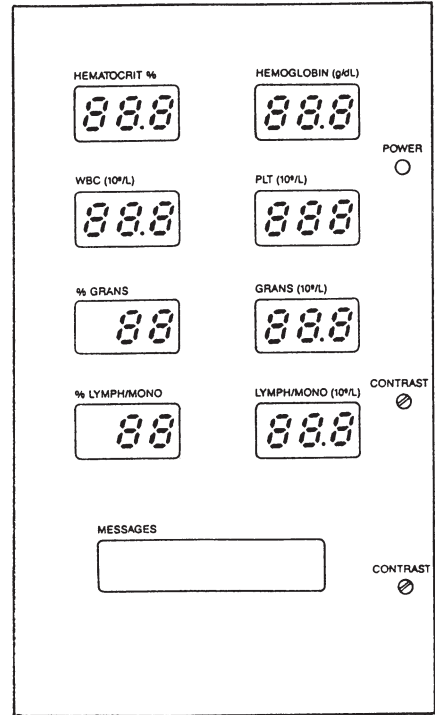
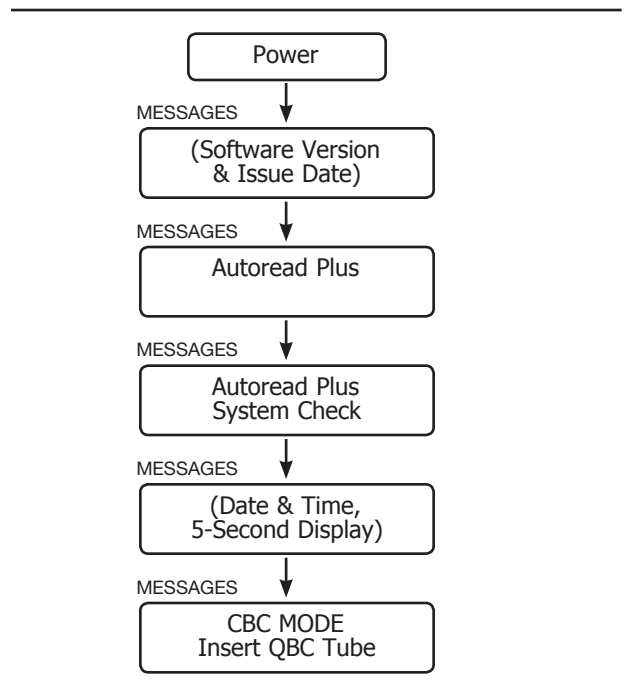

Figure 4-1.
Momentary Displays Check



4.1.2 Mode Selection

Upon completing the startup sequence, the Autoread Plus analyzer defaults or autoprograms to the hematology testing mode, i.e., CBC MODE (see Figure 4-2).

Depending on the desired operation, press the [MODE] key to access any one of the following modes:

- **CBC MODE**
Insert QBC Tube
- **CAL CHECK MODE**
Insert Calibration Rod
- **CONTROL MODE** (for hematology control)
Insert QBC Tube
- **OPTIONS MODE**
Select [▲] [▼] (to Set Date and Time, Set Print Format, Cartridge Type, and Set Baud Rate)

4.1.3 Pre-Test Performance Check

Each day before running patient specimens, verify instrument performance by assaying the calibration check rod. Press the [MODE] key to select the CAL CHECK MODE. Insert the calibration check rod **either way**; the analyzer will compensate for direction.

Refer to Section 4.5.1. for details on performance verification with the calibration check rod. QBC Hematology Control can also be tested at this time (see 4.5.2).

4.2 HEMATOLOGY TESTS

Detailed directions for blood collection and preparation of QBC tubes for hematology tests are provided in Sections 5 and 6 and Appendix A-1 of this manual.

All QBC blood tubes must be inserted in the analyzer as shown in Figure 4-3, i.e., with the closure or stopper facing left and the open end facing the optic compartment.

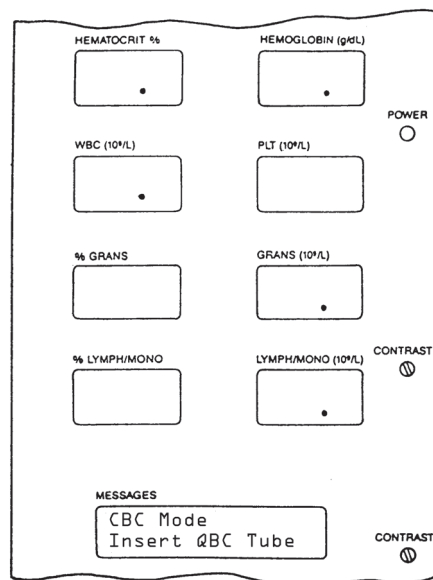

Figure 4-2.
Panel Status for Hematology Testing

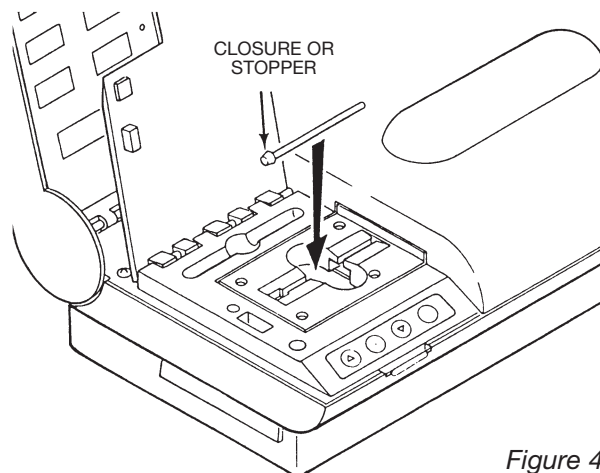



Figure 4-3.
Correct orientation for inserting QBC Blood Tubes

4.2.1 Selecting Patient's Normal Range

For a printout of test results superimposed on a pictogram of the normal hematology range of the patient, program the applicable normal range into the analyzer *before running each test* as described below.

With the display reading CBC MODE as shown opposite, use the [▲] or [▼] key to scroll through the following menu of sex-specific adult or age-specific pediatric normal ranges:

- Adult Female
 - Adult Male
 - Age: 6 Years-Puberty
 - Age: 2-6 Years
 - Age: 6-24 Months
 - Age: 2-6 Months
 - Age: 4-8 Weeks
 - Age: 1-4 Weeks
 - Age: 2-7 Days
 - Age: 24-48 Hours
 - Age: 12-24 Hours
 - Age: 0-12 Hours
- 
- Pediatric

When the desired range is on display, close the loading platform door to start the assay. If the loading platform door is closed *without making a normal range selection*, the adult male and female normal ranges will both appear on the printout.

IMPORTANT: Selection of any of the pediatric normal ranges will prevent printout of hematology diagnostic reminders (in software cartridges programmed for HDR).

Note: The QBC tube can be inserted into the loading platform before or immediately after selecting the normal range.

4.2.2 Starting An Assay

An assay is started as soon as the loading platform door is closed. Upon closing the door the display will promptly advance to ASSAY IN PROGRESS.

MESSAGES

CBC MODE
Insert QBC Tube

4.2.2 Starting An Assay (continued)

As shown in the message sequence opposite, current status of the assay is maintained on the display until test values appear.

IMPORTANT: Once a test is started, do not open the loading platform door until the test is completed and results are displayed. **Opening the door while an assay is in progress will cause the test to abort.**

To repeat an aborted assay, close the door; wait for the tube to return to the loading platform, and remove the tube. Reinsert the tube, program the normal range and close the door again to repeat the assay. Figure 4-4 shows a typical display of test results for the nine analyzer parameters. Identification of the QBC tube type – AccuTube, venous or capillary – appears on the bottom line of the message display. For a description of test printouts, see 4.2.3.

4.2.3 Hematology Printouts

(Note: Some aspects of the following section may not specifically pertain to Autoread Plus systems with USB printers. Consult the included insert labeled "IMPORTANT INFORMATION" and your printer manual for additional information in these cases.)

If the printer is connected and *On Line*, a printout of test results is initiated simultaneously with the display of test results on the front panel. Contents of the printout are determined by the format programmed earlier (Section 2.4.4), i.e.:

- Test Values Only
- Test Values plus Short HDR
- Test Values plus Long HDR
- No Printout
- Page or Label

Notes: (1) If printing format was not pre-programmed, the printout will contain only test values. (2) No HDR report is printed for pediatric tests.

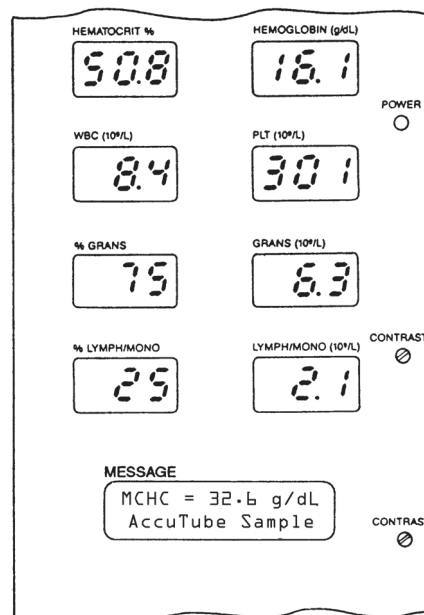
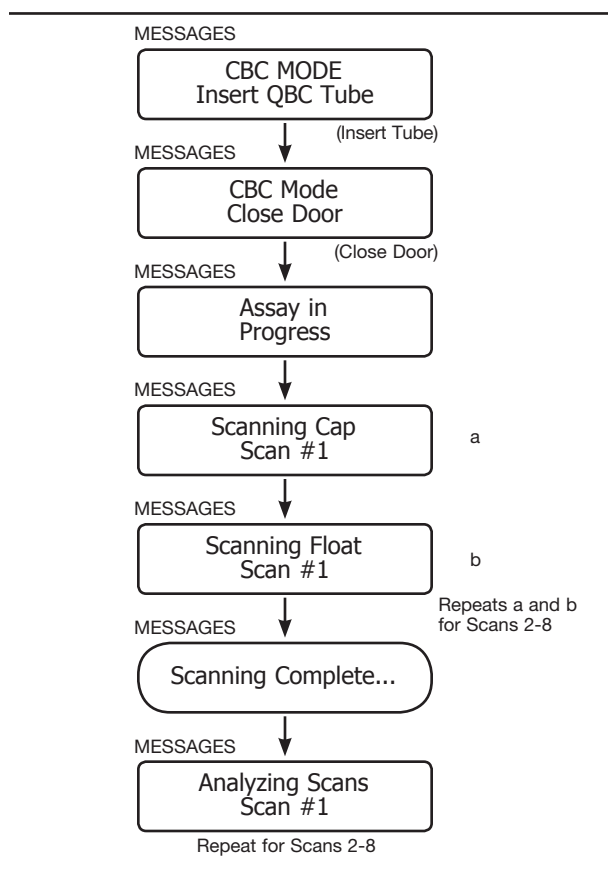

Figure 4-4.
Sample Panel Display of Test Values

4.2.3 Hematology Printouts (continued)

The example in Figure 4-5 shows test results printed numerically and in bar graph form on the normal range programmed as described in paragraph 4.2.1. On all test result printouts, spaces are provided for recording the patient's name, date of birth, and accession or ID number.

Note: In the pediatric test shown, because of a high (or low) absolute count of one or both of the WBC differentials, the printout will include the caution statement at the bottom of Figure 4-5. The printout in Figure 4-6 shows test values accompanied by a short, or abbreviated, HDR report.

If the printer is not *On Line* when test results are displayed, the automatic printing function is disabled. In order to obtain a printout, perform the following:

- Activate the *On Line* switch on the printer; then
- Press the [NEXT] key on the analyzer.

A second copy of any printout can be obtained by pressing the [NEXT] key *while the test results are still on display*. Pressing [NEXT] also allows the operator to **temporarily** select a new printout format (for example, to change from Short to Long HDR). Printouts for succeeding tests will return to the printing format originally programmed in Section 2.4.4.

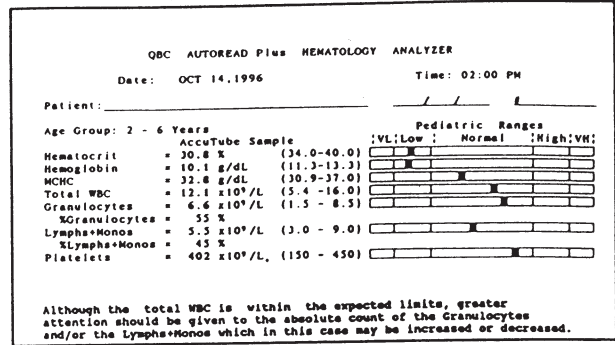

Figure 4-5. Printout, Test Values Only

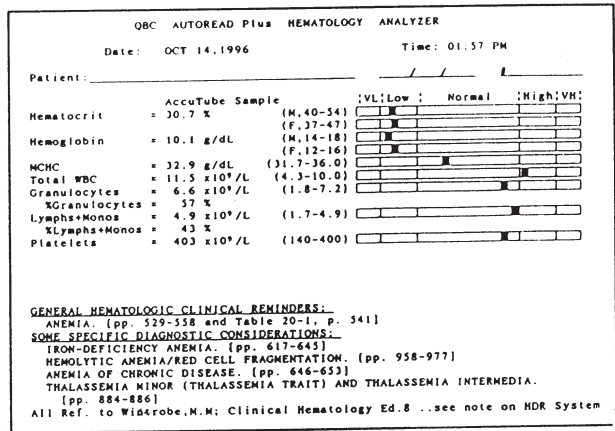
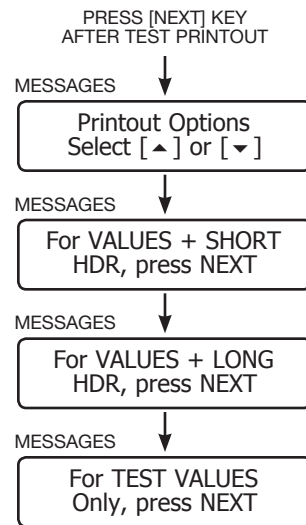

Figure 4-6. Printout, Test Values Plus Short HDR Report.

4.2.4 Assaying Additional Tubes

Results from a completed test will remain on display until the QBC tube is removed from the carriage. Upon removal of the tube, the instrument will return to the start of the operational loop of the test mode, i.e., CBC MODE. **Test results should therefore be recorded manually or printed before removing the tested QBC tube from the instrument.**

Before a repeated or new test, always enter the patient's normal range.



4.3 TEST ALERTS

4.3.1 Flashing Values and Dashes

When a test value flashes on and off on the display panel, an asterisk (*) will appear on the printout after the numerical value. Flashing values indicate that the result is outside the validated test range of the parameter. (See Table 4-1).

Dashes on the panel and on the printout mean that the computed test value is outside the display range of the instrument, or that a packed cell layer is too small to measure. In such cases, dashes and no test value and bar graph point will appear.

Table 4-1 shows out-of-range points for QBC AccuTubes. With QBC AccuTubes, elevated cell counts are indicated by the statement OUT OF RANGE on the printout and by the following displays:

- High WBC – Display flashes 99.9 (instead of ---) when total WBC count is over $99.9 \times 10^9/L$.
- High Granulocyte Count – Display flashes 99.9 when Granulocyte count is over $99.9 \times 10^9/L$.
- High Lymph/Mono Count – Display flashes 99.9 when Lymph/Mono count is over $99.9 \times 10^9/L$.
- High Platelet Count – Display flashes 999 when Platelet count is over $999 \times 10^9/L$.

See Appendix A-2 for out-of-range points for other QBC tube types.

4.3.2 Special HB-MCHC Conditions

No HB and MCHC values will appear if any of the conditions listed in Table 4-2 occur. In such cases, the examination of a peripheral blood smear is recommended to determine the nature of the red cell abnormality.

Table 4-1.

Out-of-Range Points for Flashing Test Values – AccuTube	
HCT	< 15% or > 65%
PLT*	< 20 or > 999
WBC*	< 1.6 or > 99.9
GRANS*	< 0.8 or > 70
LYMPH/MONOS*	< 0.8 or > 99.9

*10⁹/L

Table 4-2.

HB-MCHC No-Value Conditions	
HCT	≤ 15% or ≥ 65%
HB	≤ 5 g/dL or ≥ 20 g/dL
MCHC	≤ 25 g/dL or ≥ 37.3 g/dL

4.4 ERROR MESSAGES

When the analyzer detects an error or irregular condition, a message or code is displayed to identify the problem. A list of error messages is provided in Table 4-3.

The error messages are categorized by the mode or operating sequence in which they can occur. Corrective action is in some cases obvious (i.e., wrong tube was inserted); for others, service must be requested to repair a failed component; still others (e.g., during scanning) require a more detailed analysis.

4.5 SYSTEM CHECKS

4.5.1 Calibration Check Rod

The calibration check rod is designed to verify satisfactory performance of the analyzer before testing patient samples.

The calibration check rod should be tested daily following the startup self-check procedures. The calibration check rod, however, can be tested any time. As indicated in the message routine opposite, once the CAL CHECK MODE is accessed and the calibration check rod inserted, the assay proceeds in the same manner as a QBC blood test (see 4.2.2). Upon completion, results are displayed and automatically printed out.

The calibration check printout (see opposite) indicates whether the check results are acceptable, i.e., whether they fall within the factory calibration ranges printed on the insert supplied with the calibration check rod. If results are high or low, the calibration check rod should be inspected for cleanliness and, if necessary, wiped with alcohol, dried and re-tested.

Failure to obtain results within the factory calibration range after cleaning indicates a possible malfunction of the analyzer. In such cases, request service.

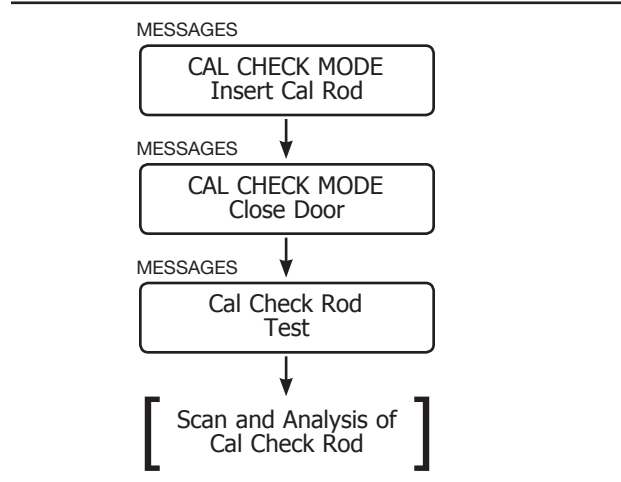
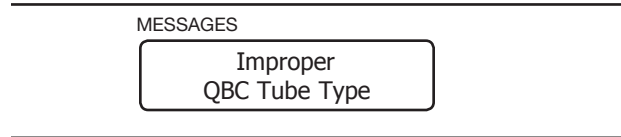

QBC AUTOREAD Plus HEMATOLOGY ANALYZER				
Date: JUNE 11, 1996		Time: 11:51		
Patient: Calibration Check Rod				
	Factory Calibration Ranges	Low	Acceptable	High
Hematocrit	= 35.1 % (33.1-35.7)	██████████	██████████	██████████
Hemoglobin	= 10.5 g/dL (9.2-11.4)	██████████	██████████	██████████
MCHC	= 29.9 g/dL (28.7-30.8)	██████████	██████████	██████████
Total WBC	= 17.8 x10 ⁹ /L (15.6-19.5)	██████████	██████████	██████████
Granulocytes	= 9.1 x10 ⁹ /L (8.3-10.1)	██████████	██████████	██████████
†Granulocytes	= 51 % (47 - 53)	██████████	██████████	██████████
Lymphs+Monos	= 8.7 x10 ⁹ /L (7.3 - 9.4)	██████████	██████████	██████████
†Lymphs+Monos	= 49 % (42 - 53)	██████████	██████████	██████████
Platelets	= 136 x10 ⁹ /L (116 - 162)	██████████	██████████	██████████

4.5.2 QBC Controls

QBC Hematology Control (p/n 424304) is available for performance monitoring of the Autoread Plus system. The control kit is shipped at regular intervals and contains two levels of control material, along with instructions for preparing and testing control tubes and an assay sheet showing expected results.

Good laboratory practice suggests that controls be run to assist in monitoring the performance of the total test system. For users in the United States, the Clinical Laboratory Improvement Amendments (CLIA) requires that controls be used for each day of patient testing. For more information on CLIA requirements, please consult www.phppo.cdc.gov/clia/regs.

All types of QBC tubes – AccuTubes and standard – can be tested with the control material. To test QBC AccuTubes, use the [MODE] key to program the analyzer to the Control mode shown opposite; then insert the control-filled tube. Review the instructions sent with the control to determine which analyzer mode should be used for testing other QBC tube types.

An eight-scan measurement and analysis procedure occurs, identical to the display routine for QBC blood tubes in Section 4.2.2. Control results appear on the display panel and printout.

Refer to the instructions and assay values supplied with the control kit for identification of the hematology parameters and acceptable ranges to be obtained with QBC Control.

QBC Extended Range Controls (p/n 424305) are also available. United States users are required to run these controls every six months to meet CLIA requirements for calibration verification.

Extended Range Controls are available on an as-needed basis. The kit contains 3 levels of control material along with instructions for preparing and testing control tubes, and an assay sheet showing expected values.

4.5.3 QBC Proficiency Tests

Proficiency testing is an external evaluation of the quality of a laboratory's performance. Laboratories enrolled in a proficiency testing program will receive five unknown samples, three times a year. These samples are tested in the same way that patient samples are tested. The results are submitted to the proficiency testing program for comparison to results obtained by other laboratories in your peer group. Below is a list of proficiency testing service companies.

CAUTION

Check the instructions accompanying the survey samples to determine which Autoread Plus analyzer mode should be used for testing them. Follow the data entry instructions provided by the proficiency service. Be sure to enter the correct tube type and analyzer type in the appropriate places.

Groups Offering QBC Hematology Proficiency Testing Services (Partial Listing):

- **American Proficiency Institute (API)**
1159 Business Park Drive
Traverse City, MI 49686
800-333-0958
www.api-pt.com
- **American Academy of Family Physicians (AAFP)**
PT Program Coordinator
11400 Tomahawk Creek Parkway
Leawood, KS 66211
800-274-2237
www.aafp.org
- **American Association of Bioanalysts (AAB)**
205 West Levee
Brownsville, Texas 78520
800-234-5615
www.aab.org
- **American College of Physicians (ACPS)**
2011 Pennsylvania Ave. NW, Suite 800
Washington, D.C. 20006
800-338-2746
www.acponline.org
- **College of American Pathologists (CAP)**
Surveys Department
325 Waukegan Road
Northfield, Illinois 60093
800-323-4040
www.cap.org

4.6 OPTION FUNCTIONS

The OPTIONS MODE is accessed by means of the [MODE] key. Use the [▲] or [▼] key to scroll through the menu of options shown opposite.

The first three functions are described earlier in Section 2.4.2-2.4.4 of this manual. The CARTRIDGE TYPE function may be needed in connection with service problems. Before requesting technical assistance on any problem relating to the analyzer, obtain the identification number of the installed software cartridge by accessing the CARTRIDGE TYPE function; then press the [NEXT] key and record the software version number.

Note: The software number is also displayed during the start-up routine and appears on the software cartridge label.

See Section 2.5.1 for a description of the SET BAUD RATE option.

To exit any option function, press [MODE] to advance the display to the primary CBC MODE.

4.7 QBC CAPILLARY CENTRIFUGE

QBC hematology tests require the centrifugation of blood samples at the specified RCF for 5 minutes to obtain proper cell banding. The QBC Capillary Centrifuge is designed to fulfill this requirement.

When using the QBC Capillary Centrifuge, be sure to place tubes on the centrifuge rotor in a balanced array (see example in Figure 4-8).

Detailed operating instructions and calibration check procedures are described in the QBC Capillary Centrifuge operator's manual.

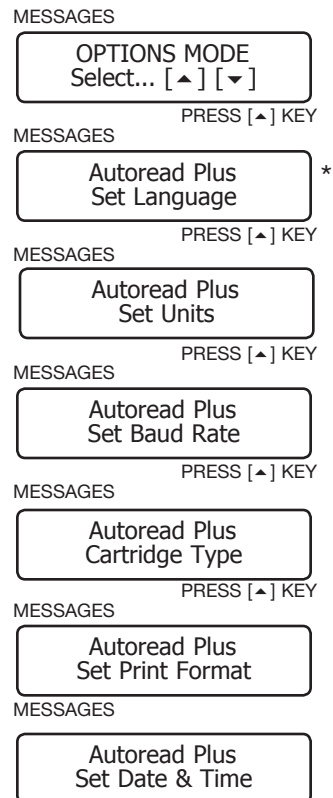

* IN APPLICABLE SOFTWARE

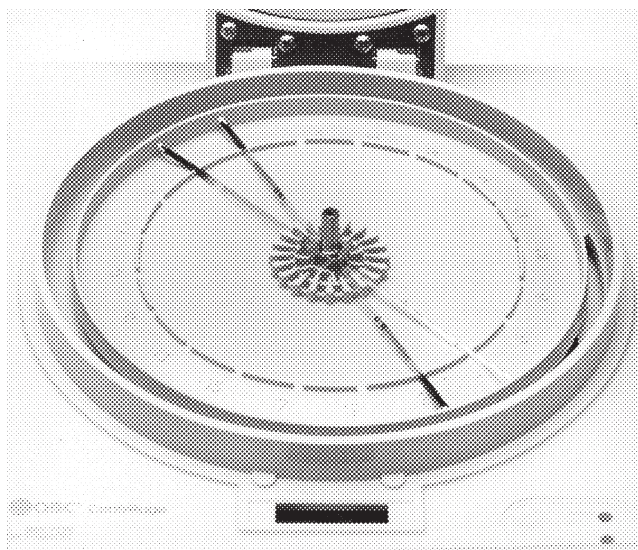

Figure 4-8.
QBC Tubes with Balance Tube in Even (#4) Position

Table 4-3

ERROR MESSAGE	DURING STARTUP AND SELF-TEST			CAUSE AND ACTION
	DURING CALIBRATION CHECK	DURING HEMATOLOGY TESTS*		
Lamp Test Failed	●			Cause: Display message will flash if software determines the Lamp is either open or shorted. Action: Request service.
Checksum Error 1	●			Cause: Defective cartridge. Action: Turn Power switch off, remove cartridge, and re-install, turn Power on and try again. If error persists, order a replacement cartridge.
Checksum Error 2	●			Cause: Defective cartridge. Action: Turn Power switch off, remove cartridge, and re-install, turn Power on and try again. If error persists, order a replacement cartridge.
Calibration Error (backlash)	●			Cause: Loose motor coupling, or carriage not moving freely. Action: Request service.
Filter Wheel Error (1) <small>Also #2, #3, #4, #5 & #6</small>	●			Cause: Defective filter wheel, defective LED, carriage not moving, or defective circuit board. Action: Request service.
Position Error [Remove Tube] <small>*With Buzzing noise</small>	●	●	●	If message occurs on powering up, error is a holdover from the last procedure. Cause: During carriage return, tube ejected improperly by collet. Action: Open door; carefully remove tube with forceps. Follow display messages by pressing [NEXT] key, then <i>simultaneously</i> pressing [▲] and [▼] keys.
Carriage Error (no sensor)	●	●	●	Cause: Transport mechanism is not moving due to a: 1) defective power pack; 2) jammed carriage; or 3) defective circuit board. Action: Request service.
Rotation Error		●		Cause: Incorrect or damaged calibration check rod. Damaged collet. Optics require service. Action: Verify use of correct Call Check Rod. Wipe clean and retest. If message persists, request service.
Cal Rod Error (03)		●		Cause: Incorrect or damaged calibration check rod. Damaged collet. Optics require service. Action: Verify use of correct Call Check Rod. Wipe clean and retest. If message persists, request service.
Improper QBC Tube Type			●	Cause: Mode on instrument incorrect for sample being tested (i.e. calibration check rod tested in CBC or Insert QBC Tube mode). Action: Remove tube and insert correct type... or access correct test mode.
*Cannot ID QBC Tube Type			●	Cause: Severely hemolyzed specimen, severe platelet clumping on top of float, improperly prepared tube, missing float, tube filled backwards, smudged tube, missing fill lines, or wrong tube type. Action: Remove tube and inspect. Retest or prepare and test new tube.
Error Locating Bottom of RBC's			●	Cause: Closure or stopper in QBC tube is incorrectly sealed, or LED is defective. Action: Prepare and test new tube. If message persists, request service.
*Error Locating Float			●	Cause: Severely hemolyzed specimen, defective float, float lodged in wrong part of tube, improperly prepared tube, defective lamp, or defective LED. Action: Remove tube and inspect. Retest or prepare and test new tube. If message persists, request service.

*Patient, Proficiency and Control Samples

Table 4-3 (continued)

Error Messages and Codes

ERROR MESSAGE	DURING STARTUP AND SELF-TEST			CAUSE AND ACTION
		DURING CALIBRATION CHECK	DURING HEMATOLOGY TESTS*	
*Error Locating Meniscus			●	<p>Cause: Improper tube inserted, defective lamp, or binding carriage. Action: Remove tube and inspect. Retest or prepare and test new tube. If message persists, request service.</p>
*Improper Fill Venous Sample			●	<p>Cause: Venous tube not filled with required amount of blood or some sample was lost during tube preparation. Action: Check pipetter for accuracy of fill. Prepare and test new tube.</p>
*Improper Fill Capillary Sample			●	<p>Cause: Capillary tube not filled with required amount of blood or some sample was lost during tube preparation. Action: Prepare and test new tube.</p>
*Improper Fill AccuTube Sample			●	<p>Cause: AccuTube not filled with required amount of blood or some sample was lost during tube preparation. Action: Verify AccuTube spacer in place if using pipetter. Prepare and test new tube.</p>
Too Many Bubbles Found in Tube			●	<p>Cause: Plasma contains excess bubbles, making accurate measurement of plasma column difficult. Action: Prepare and test new tube.</p>
*Granulocytes Unreadable (1) <small>Also #2, #3, #4, #5 & #6</small>			●	<p>Cause: Errors (1) and (2): Sample has blurred red cell-granulocyte interface. Errors (3-5): Sample has severely blurred red cell-granulocyte interface. Action: Instrument will not report GRANS, WBC, or % LYMPH/MONOS, but will report LYMPH/MONO (10⁹/L), PLT, HCT, HB, and MCHC. For full test panel, test fresh sample or use other test method.</p>
*Buffy Coat Unreadable (2)			●	<p>Cause: Pancytopenia, resulting in extremely small, hard-to-read cell layers. Action: Inspect tube for small layers; if capillary sample, obtain and test <i>venous</i> sample. Cause: Various leukemias result in extremely large layers of certain white cells which obscure other small cell layers (e.g., lymphocytes). Action: Inspect tube for large layers; if venous sample, obtain and test <i>capillary</i> sample.</p>
*Buffy Coat Unreadable (3)			●	<p>Cause: Top of platelet layer is near or at top of float, caused by extremely large layer of platelets, lymph/monos, or granulocytes. Action: Inspect tube for large layers; if venous sample, obtain and test <i>capillary</i> sample.</p>
*Buffy Coat Unreadable (4)			●	<p>Cause: Platelets clumped on top of float, possibly due to poor blood collection technique or to age of blood sample. Action: Obtain a fresh sample and retest.</p>
*Buffy Coat Unreadable (5)			●	<p>Cause: Lymph/Mono layer is extremely small or is inadequately stained. Action: Retest or prepare and test new tube.</p>
*Buffy Coat Unreadable (6)			●	<p>Cause: analyzer fails to find 4 out of the 8 scans of the float that yield reproducible cell counts, possibly due to expired QBC tube or incorrect sample preparation. Action: Retest or prepare and test new tube.</p>

*Patient, Proficiency and Control Samples

QBC[®] Diagnostics Systems Technical Bulletin

Date Issued: January 2006

Product: QBC AUTOREAD™ (Model #424576)
QBC AUTOREAD PLUS™ (Model #429576)

Subject: Printing Diagnostic Scans **(Troubleshooting Tool Only)**

Diagnostic Scan printouts are used as a troubleshooting tool by the QBC Diagnostics[®] Technical Services Department. Blood samples from Patients, QBC Controls & Proficiency Test material can be evaluated, for troubleshooting purposes only, using this diagnostic procedure. Diagnostic Scan information can be obtained from the QBC AUTOREAD™ & QBC AUTOREAD PLUS™ Hematology Systems through the following procedure:

1. Using the appropriate test mode, process the QBC tube and allow it to print the standard QBC report.
2. When the standard QBC report is finished printing, leave the QBC tube in the instrument with the results on the display screen. Depress the MODE and DOWN ARROW KEY at the same time in order to initiate the printing of the Diagnostic Scan (note: depress the keys for 1-2 seconds and then release). For best results during faxing, Diagnostic Scan printouts should be on an 8 ½" x 11" sheet of plain white paper.
3. The QBC AUTOREAD & QBC AUTOREAD PLUS will print a second page containing three (3) boxes with graphs, followed by several rows of numbers. The QBC AUTOREAD & QBC AUTOREAD PLUS will display "Now Printing" in the message window as the information is being printed.
4. Fax the "Diagnostic Scan" information to QBC Diagnostics Technical Services at +1-814-692-7662. Prior to faxing the scans, please call the QBC Diagnostics Inc. Technical Services Department at 1-866-265-1486 (toll free), or +1-814-692-7661. Inform one of the Technical Specialists that you are faxing Diagnostic Scan information for review.
5. Please provide the following information with the fax: Lot Number and Expiration Dates and type of QBC tube being used, QBC Model Number and Serial Number (Model and Serial Numbers for the QBC AUTOREAD / QBC AUTOREAD PLUS are located on the bottom of the unit). Additionally, please include the sample type being tested (i.e., QBC Control or other vendor's control, Proficiency Test or patient blood sample). Please use a coversheet that includes your name, office name and a return phone number.

4.9 QBC PIPETTER

The QBC pipetter (Figure 4-9) is a fixed-volume device, designed to aspirate 111.1 μL of blood to fill standard QBC venous tubes. An AccuTube spacer is used to adjust the fill volume to 70 μL when using QBC AccuTubes.

The QBC pipetter incorporates a movable barrel as shown in Figure 4-10. The barrel is opened by twisting it forward. When opened, the pipetter accepts the stoppered end of an AccuTube, or the open end of a standard QBC venous tube. When closed, the pipetter holds the tube in place and seals it around its outside, permitting a vacuum to be drawn.

Insert tubes **gently** into the open barrel. Pushing forcefully will prematurely seat the stopper of an AccuTube. Once inserted, close the barrel by twisting it backward.

Depress plunger. Insert QBC Tube into well-mixed blood. Release to fill.

Tilt pipetter upward. Twist barrel forward to OPEN, remove QBC Tube.

Note: To prevent damage to laboratory gloves, hold the barrel at the ribbed area when turning (see Figure 4-11).

IMPORTANT: Always leave the barrel open when the pipetter is not in use.

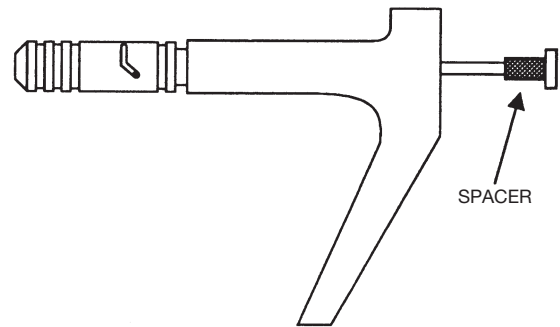

Figure 4-9.
QBC Pipetter

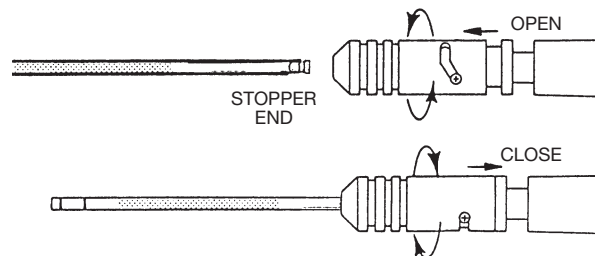

Figure 4-10.
Barrel of QBC Pipetter

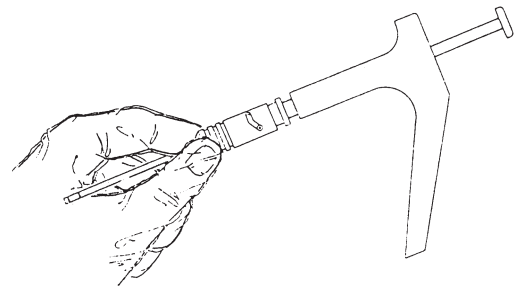

Figure 4-11.
Correct Barrel Adjustment Location

4.10 PRECAUTIONS AND HAZARDS

ELECTRICAL SAFETY

- **Power Connections:** Plug the cordsets of the power pack, centrifuge, and printer only into AC receptacles rated at the voltage and frequency specified on the data plates.
- **Grounding:** Never remove the grounding prong from the cordset plugs of the power pack, centrifuge, and printer.
- **Repairs:** Always unplug the power cord before attempting any repairs or service.
- **Defective Cords:** If a power cord or plug is damaged, promptly request replacement service.

HANDLING PRECAUTIONS

- **Biohazards:** Blood specimens may contain the Hepatitis B Virus (HBV), Hepatitis C Virus (HCV), Human Immunodeficiency Virus (HIV), or other disease-causing agents. Handle all patient specimens as potential biohazards capable of transmitting infection. Wear appropriate personal protective equipment, including gloves, when collecting and processing blood.
- **QBC Tube/Centrifugation:** QBC Blood Tubes are made of glass. Be careful when handling and preparing tubes to prevent breakage and possible injury. Inspect QBC Tubes before use. DO NOT use cracked or scratched tubes. Always install the rotor cover tightly before centrifuging blood tubes to prevent breakage.
- **Position Error Message:** Always use forceps to remove tube from instrument. Carefully follow instructions or message display to prevent breakage of tube inside instrument.
- **Tube Breakage:** If a QBC tube breaks, carefully pick up broken glass with a hemostat or other device, using puncture-resistant utility gloves.
 - If a tube breaks inside the centrifuge, wipe the head and interior of the cover clean with a cloth and a 1:10 dilution of chlorine bleach. Allow to dry. Note: Do not pour water or bleach solution into the centrifuge itself.
 - If a tube breaks inside the analyzer, remove the waste tray below the loading platform and discard any broken glass. Clean the **waste tray** with a 1:10 dilution of chlorine bleach; then rinse with water and dry.

Section 5

Specimen Collection and Preparation for Testing

5.1 VENOUS BLOOD FOR HEMATOLOGY

Draw venous blood into collection tubes containing the anticoagulants disodium or tri-potassium ethylenediamine-tetraacetate (EDTA).

5.1.1 Collection Procedures

- Be sure to wear laboratory gloves. Use only clean glassware and sterilized collecting instruments. Before venipuncture, clean the skin area with an antiseptic agent and wipe dry.
- Draw venous blood with a Vacutainer™ brand blood collection tube* or other blood-drawing device containing EDTA. To assure an acceptable blood-to-anticoagulant ratio, fill the collection tube to at least 2/3 of its fill volume. *Remove the collection needle and dispose properly in a sharps container.*
- Thoroughly mix the blood with the anticoagulant. **If clots are present, discard the specimen.**

5.1.2 Anticoagulants

Always anticoagulate venous blood with disodium or tri-potassium EDTA. **The use of other anticoagulants is not recommended.**

5.1.3 Interfering Substances – QBC AccuTubes

- Hemolysis: Do not perform tests on visibly hemolyzed blood specimens.
- Bilirubin: No effects on test results have been observed at bilirubin concentrations up to 20 mg/dL.⁹
- Triglycerides: No effects on test results have been observed at triglycerides concentrations up to 1,800 mg/dL.⁹
- Coumadin: Anticoagulant therapy has been shown to have no clinically significant effect on performance.⁹
- Doxorubicin: Treatment with the anthracyclic drug Doxorubicin does not appear to interfere with the QBC test method.⁹
- Other drugs: The effects of other potentially interfering drugs and their metabolites on QBC tests have not been established.^{10,11}

Interfering substances information for all other QBC tube types can be found in Appendix A-1.

WARNING

Blood specimens may contain the Hepatitis B Virus (HBV), Hepatitis C Virus (HCV), Human Immunodeficiency Virus (HIV), or other disease-causing agents. Handle all patient specimens as potential biohazards capable of transmitting infection. Wear appropriate personal protective equipment, including gloves, when collecting and processing blood.

**Product of BD Vacutainer Systems*

5.1.4 Specimen Storage and Stability – QBC AccuTubes

Venous blood samples may be stored at room temperature 68° to 77°F (20° to 25°C) for up to 8 hours prior to preparation of AccuTubes. Samples that cannot be tested immediately must be refrigerated if the room temperature is above 77°F (25°C). Refrigerated samples stored at 36° to 46°F (2° to 8°C) are stable for up to 8 hours. Bring samples back to room temperature before you prepare an AccuTube. The AccuTube should be centrifuged within 15 minutes after the plastic float is inserted. Once tubes are centrifuged, the AccuTube is stable for 4 hours before testing, providing the AccuTube is stored vertically with stopper end down and away from heat and intense light.

Specimen storage and stability information for all other QBC tube types can be found in Appendix A-1.

5.2 CAPILLARY BLOOD FOR HEMATOLOGY

Fill QBC AccuTubes or other QBC capillary blood tubes directly from a finger puncture or, in infants, a heel puncture (see below). AccuTubes and capillary blood tubes contain dry anticoagulant coatings, which must be mixed after filling as described in the test procedures in Section 6 and Appendix A-1.

5.2.1 Collection Procedures

- For finger puncture blood, the finger must not be cyanotic or edematous. If cyanotic or cold, immerse hand in warm water (30°C to 40°C) for 3 to 5 minutes before puncture, or use a moist compress or warm pack.
- The lateral or medial plantar surface of the heel is an acceptable capillary blood collection site for infants less than one year old.
- Clean finger or heel area with antiseptic agent and wipe dry.
- Puncture finger or heel with sterile lancet, wipe away first drop of blood, and immediately collect next drop or two directly in QBC AccuTube or capillary blood tube. Specimens taken after first several drops may yield lower platelet counts, since platelets may adhere to wound site or may aggregate in the drop of blood.

- Slight pressure can be applied some distance from finger puncture. Avoid squeezing puncture area to prevent diluting blood with tissue fluid.

5.2.2 Anticoagulants

QBC AccuTube and QBC capillary blood tubes are internally coated with sodium heparin and di-potassium EDTA and require no additional anticoagulants.

5.2.3 Interfering Substances

See Paragraph 5.1.3 under Venous Blood. Interfering substances information for all other QBC tube types can be found in Appendix A-1.

5.2.4 Stability of QBC Capillary Tubes

Filled QBC AccuTubes and other QBC capillary blood tubes should be mixed and centrifuged promptly after blood collection.

Section 6

Test Procedure – QBC AccuTube™

6.1 MATERIALS PROVIDED

The Autoread Plus Hematology System consists of the following instruments and accessories with which to perform hematology tests:

- QBC Autoread Plus Analyzer with software cartridge
- QBC Power Pack
- QBC Capillary Centrifuge
- Printer
- Calibration Check Rod
- Workstation
- Forceps
- QBC Pipetter with AccuTube Spacer

6.2 MATERIALS REQUIRED BUT NOT PROVIDED

- QBC AccuTubes
100 Tests 423406
- Lint-free tissue

6.3 HEMATOLOGY TEST PROCEDURE WITH QBC ACCUTUBE

- Be sure QBC blood tubes have not exceeded their labeled expiration date or open vial stability.
- Maintain laboratory temperature at 68° to 98°F (20° to 37°C).
- Venous blood: specimen must be well-mixed and at room temperature.
- Capillary blood: collect only from free-flowing finger puncture or plantar surface of heel in infants less than one year old.

WARNING

Acridine orange reagent may be toxic; do not ingest. Avoid contact with skin, eyes, and clothing.

WARNING

Blood specimens may contain the Hepatitis B Virus (HBV), Hepatitis C Virus (HCV), Human Immunodeficiency Virus (HIV), or other disease-causing agents. Handle all patient specimens as potential biohazards capable of transmitting infection. Wear appropriate personal protective equipment, including gloves, when collecting and processing blood.

WARNING

QBC blood tubes are made of glass. Be careful when handling and preparing tubes to prevent breakage and possible injury. Inspect QBC AccuTubes before use. Do not use cracked or scratched tubes.

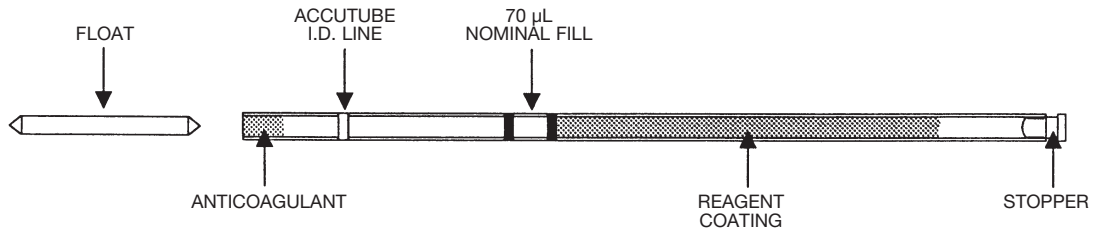

Figure 6-1.
AccuTube with Partially Seated Stopper and Separate Float

6.3.1 Description

The AccuTube (Figure 6-1) can be filled with either venous or capillary blood and incorporates an identification line, graduated fill lines, precoated reagents, and a partially seated stopper. It is filled with capillary blood by capillary action or with venous blood by capillary action or by means of a QBC pipetter fitted with an AccuTube spacer. Nominal fill of the AccuTube is 70 µL with either blood specimen. After mixing the specimen and seating the stopper, the plastic float is inserted, and the tube is centrifuged for 5 minutes. The centrifuged tube is placed in the Autoread Plus analyzer for automatic scanning and reporting of results.

6.3.2 Preparation and Handling of AccuTubes

Running a Patient Sample

Step 1: Fill the AccuTube

Note: Do not allow the blood to touch the AccuTube rubber stopper while performing this step.

Venous Blood – Gently mix the sample at least 6 times by inversion, or for 5 minutes on a mechanical mixer immediately before filling the AccuTube. Tilt the blood tube as shown, and place the open end of the AccuTube in contact with the blood. Fill the AccuTube to between the two black fill lines. Wipe the outside of the AccuTube with lint-free tissue.

Note: For instructions on use of the pipetter, refer to Section 4.8.

Capillary Blood – Place the open end of the AccuTube in contact with the finger puncture blood. Hold the AccuTube close to horizontal to avoid air bubbles. Fill the AccuTube until the blood level is between the two black lines. Wipe the outside of the AccuTube with lint-free tissue.

**Avoid air bubbles when filling.
Mix blood well with coating**

Step 1 Fill Tube (venous)

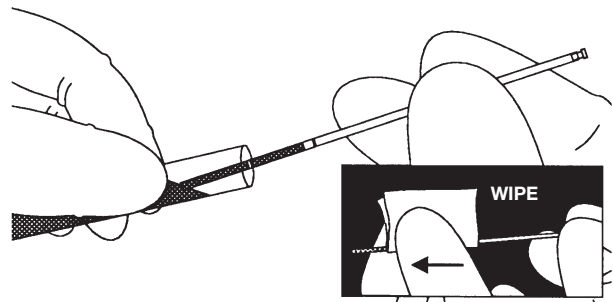

Step 1 Fill Tube (capillary)

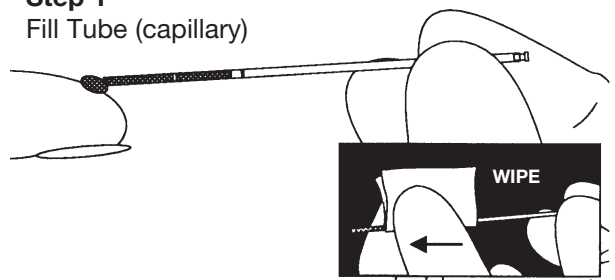

Step 2: Rock the AccuTube to Mix

Note: Do not allow the blood to touch the AccuTube rubber stopper while performing this step. If blood stops moving, loosen or remove the stopper and finish mixing, then re-insert the stopper.

Hold the AccuTube in the center. Rock the AccuTube back and forth at least 5 times. Move blood end to end to mix well with orange coating.

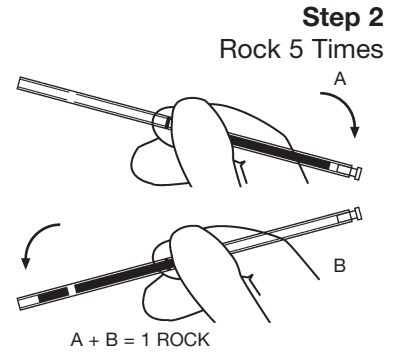

Step 3: Seat the Stopper

Turn the AccuTube upright. Hold the AccuTube near the stopper end. Seat the stopper by pressing down firmly on a hard surface. At this point, the blood can touch the stopper.

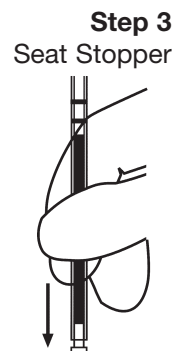

Step 4: Insert the Float

Note: Do not touch the floats with your fingers.

Slide the open end of the AccuTube over a float until the float is partially inserted. Gently lift the AccuTube up and out of the *SoftGrip*. Push float against the back of the package to fully insert.

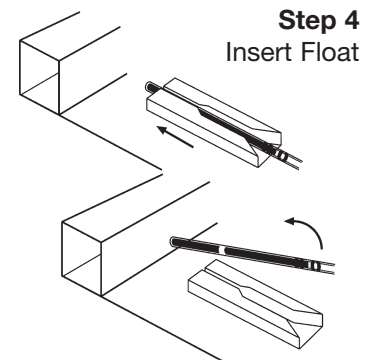

Step 5: Centrifuge the AccuTube

Open the centrifuge lid and remove the metal cover. Hold the AccuTube so the rubber stopper is toward the outside edge of the rotor. Place the AccuTube in the centrifuge. Balance the rotor by placing an AccuTube (balance tube may be empty or full) in the slot opposite the patient AccuTube.

Place the metal cover over the rotor and screw in place until finger tight. **DO NOT OVER TIGHTEN!!** Close the lid and press ON/OFF button. The centrifuge will spin for 5 minutes. The lid will unlatch when the centrifuge stops. Open the lid, unscrew the metal cover and remove the AccuTubes.

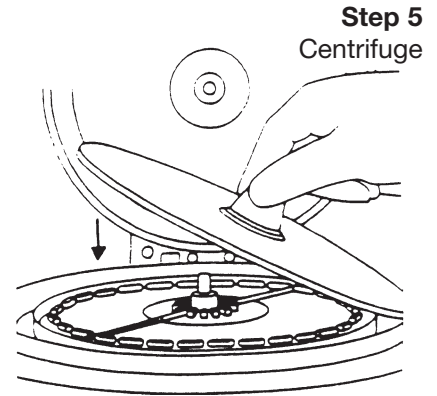

Step 6: Analyze the Sample

Select the CBC MODE on the QBC Autoread Plus analyzer. Open the analyzer door and place the AccuTube in the analyzer with the rubber stopper to the left. Close the analyzer door to start the test.

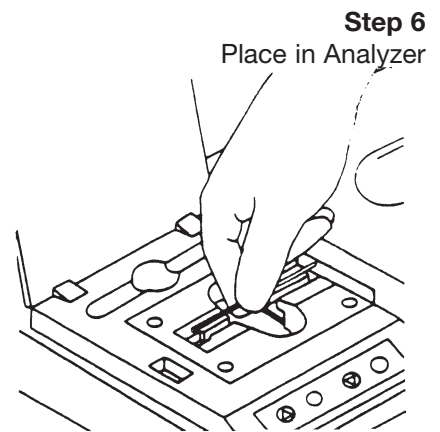

Step 7: Obtain Results

When the test is complete, the results will be displayed on the analyzer and printed. Test results are cleared from the display when the analyzer door is opened. Do not open the analyzer door until the results are reviewed and additional printouts are made. Open the analyzer door and remove the AccuTube. Discard the tube in a biohazard sharps container.

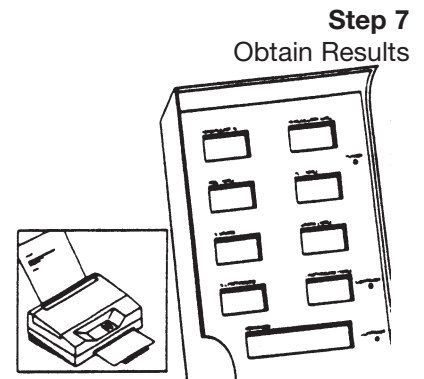

6.4 BETWEEN-SPIN TIME DELAY FOR ACCUTUBES

Since possible exposure of blood samples to heat buildup in the centrifuge rotor compartment can adversely affect cell layering, wait at least 3 minutes between successive spins if the ambient temperature is between 68°-90°F (20°-32°C). If the ambient temperature is between 90°-98°F (32°-37°C), a 15 minute wait period is required to allow for sufficient cooling of the rotor. Between each spin, be sure the rotor cover is removed and the rotor is empty.

6.5 FILLING ACCUTUBES WITH VENOUS BLOOD

The QBC pipetter must be modified to draw 70 µL of sample when it is used for filling AccuTubes with venous blood. Install the AccuTube spacer by snapping the spacer over the plunger stem of the pipetter. The spacer limits the stroke of the plunger to an aspiration volume of 70 µL.

6.6 ACCUTUBE QUALITY CONTROL

Before testing AccuTube samples, perform a daily calibration check of the QBC Autoread Plus analyzer according to the procedures in the package insert supplied with the Autoread Plus calibration check rod (Cat. No. 424613).

QBC Hematology Control (Cat. No. 424304) is available for performance monitoring of AccuTubes. These controls list assay values for AccuTubes.

Proficiency testing services are also available for regular performance assessment of your laboratory. For addresses of testing groups, contact the Technical Service Department of QBC Diagnostics Inc. 1-866-265-1486 (toll free), +1-814-692-7661 or qbcsupport@qbcdiag.com.

6.7 TROUBLESHOOTING TIPS FOR ACCUTUBES

This section lists problems that may be encountered while preparing QBC AccuTubes or while operating the QBC Autoread Plus.

Problem: AccuTube is underfilled.

Action: If filling the AccuTube with a pipetter, check that the spacer is placed on the pipetter correctly. When filling the AccuTube by capillary action, check to be sure that the blood column reaches the bottom black fill line on the tube.

Problem: AccuTube is overfilled.

Action: If filling the AccuTube with a pipetter, check that the spacer is placed on the pipetter correctly. When filling the AccuTube by capillary action, check to be sure that the blood column does not go past the uppermost black fill line on the tube.

Problem: Blood touches stopper during fill, wipe and mix steps.

Action: Tip the AccuTube so that the fill end is angled down slightly. With the thumb and forefinger, gently pull on the stopper until the blood moves down the tube, away from the stopper. Seat the stopper after mixing is complete.

Problem: Stopper is seated after inserting float but before mixing tube.

Action: Prepare another AccuTube.

Problem: Stopper comes out before filling.

Action: Locate the end of the AccuTube *farthest* from the white identification line. Partially insert the stopper into this end with the thumb and forefinger. Proceed with filling.

Problem: Stopper comes out after filling.

Action: Locate the end of the AccuTube with the white identification line. With the thumb and forefinger, partially insert the stopper into the *opposite* end of the AccuTube. Use the AccuTube illustration as a guide. Continue preparing the AccuTube as described.

Problem: Float gets stuck (after centrifugation is complete).

Action: Prepare another AccuTube.

Problem: AccuTube is dropped in analyzer.

Action: Do not shut the door of the Autoread Plus. Check to see if the AccuTube is in the Waste Tray (located on the left side). If the AccuTube is not in the Waste Tray, look in the Loading Platform to see if the AccuTube is visible. If one end of the tube is visible, turn off the analyzer, use forceps, and gently lift the tube up and out of the analyzer.



For situations that require technical assistance, call:
QBC Diagnostics Inc. Technical Service
1-866-265-1486 (toll free) or +1-814-692-7661.

Section 7

System Performance – QBC AccuTubes

7.1 TEST RESULTS

7.1.1 Digit-Decimal Format

Test values generated by the Autoread Plus analyzer are displayed in the following units and decimal formats:

• Hematocrit, %	XX.X
• Hemoglobin, g/dL	XX.X
• MCHC*, g/dL	XX.X
• Platelet Count (PLT), 10 ⁹ /L	XXX
• White Cell Count (WBC), 10 ⁹ /L	XX.X
• GRANS (abs.), 10 ⁹ /L	XX.X
• GRANS (rel.), %	XX
• LYMPH/MONO (abs.), 10 ⁹ /L	XX.X
• LYMPH/MONO (rel.), %	XX

* Mean Corpuscular Hemoglobin Concentration. MCHC in grams per deciliter of red cells (g/dL) is equal to MCHC percent (%).

To convert hemoglobin to millimoles per liter, multiply the value in g/dL by 0.6206 to obtain hemoglobin in mmol/L.

When testing whole blood, irregularities detected in length measurement or computed values will cause the analyzer to display an error flag; in certain cases the test may be aborted and no results or only partial results will be displayed.

7.1.2 Operating Ranges

Hematology parameters measured with AccuTubes by the QBC Autoread Plus analyzer are valid over the following range of values:

• Hematocrit	15 - 65%
• Hemoglobin	5.0 - 20.0 g/dL
• Platelet Count	20 - 999 × 10 ⁹ /L
• WBC Count	1.6 - 99.9 × 10 ⁹ /L
• Granulocyte Count	0.8 - 70.0 × 10 ⁹ /L
• Lymph/MonoCount	0.8 - 99.9 × 10 ⁹ /L

Results that fall outside these ranges may be confirmed by alternate methods. Results that fall outside these ranges will flash on the QBC Autoread Plus display and will be preceded by an [*] on the printout.

7.2 TEST LIMITATIONS

Quality medical care requires that laboratory values be correlated with each patient's symptoms and signs by a trained practitioner.

Section 7.1.2 lists the validated upper and lower limits of the operating range. Values above and below these validated ranges should be confirmed by an alternate method.

The AccuTube has been formulated to provide optimum packing and layering of normal cells. In a small number of patients, however, the system cannot read certain parameters and will not report a value. User errors in processing or use of outdated or inappropriately stored tubes can also result in non-reported results. Practitioners must not assume that unreported values are normal; further testing with an alternative method is essential.

7.2 TEST LIMITATIONS (continued)

Automated granulocyte and lymphocyte/monocyte differential counts cannot replace the conventional manual differential. Due to the grouping by density of the cell populations by the QBC test method, the system cannot discriminate between normal and abnormal cell types in disease states characterized by the presence of abnormal white cell types or nucleated red blood cells. If abnormal cell populations are suspected, verification of QBC test results or testing and diagnosis by alternative methods is essential.

The combined lymphocyte/monocyte count should not be used to test for lymphocytopenia in evaluating patients with known or possible immunodeficiencies. Further evaluation of lymphocyte/monocyte counts in relevant situations must include a manual differential and lymphocyte subset analysis.

The presence of abnormally sized platelets may lead to discrepancies between the QBC test method platelet count, which is based on platelet mass, and results obtained with an impedance counter, which are based on measurement of particle number.

7.3 EXPECTED VALUES

The following table provides normal ranges reported in the literature.^{1,12} Offices or laboratories may choose to develop normal hematology ranges based on the characteristics of their patient population.

Parameter	Range
Hematocrit Males (%)	42-50
Hematocrit Females (%)	36-45
Hemoglobin Males (g/dL)	14-18
Hemoglobin Females (g/dL)	12-16
MCHC (g/dL)	31.7-36.0
Platelet Count ($\times 10^9/L$)	140-440
WBC ($\times 10^9/L$)	4.3-10.0
Granulocyte Count ($\times 10^9/L$)	1.8-7.2
Lymphocyte/Monocyte Count ($\times 10^9/L$)	1.7-4.9

7.4 SPECIFIC PERFORMANCE CHARACTERISTICS

7.4.1 Precision

Data on typical within-run precision tests on AccuTubes tested in the QBC Autoread Plus analyzer are shown in Tables 7-1a and 7-1b. The precision data represents the analysis of ten whole blood specimens, each assayed in replicates of 10.

Table 7-1a.

Precision		
Parameter	Mean Value	C.V.
HCT (%)	40.4	0.6 %
HB (g/dl)	13.3	0.6 %
PLT ($\times 10^9/dl$)	287	4.4 %
WBC ($\times 10^9/dl$)	8.1	6.3 %

Table 7-1b.

Precision		
Parameter	Range	S.D.
GRAN (%)	40-80	< 3.3
LYMPH/MONO (%)	20-55	< 3.3

7.4.1 Precision (continued)

In a separate precision study, intra- and inter-run precision were assessed using a dual level QBC Control (#424304). The controls were assayed on

multiple days at three sites using QBC AccuTubes and the QBC Autoread Plus System. The results of this study are presented in Table 7-2.

Table 7-2

AccuTube Precision Using QBC Control											
Parameter	Site	Mean Value	Normal Level				Abnormal Level				
			Intra-run		Inter-run		Intra-run			Inter-run	
			% CV.	df	% CV.	df	Mean Value	% CV.	df	% CV.	df
HCT (%)	#1	33.67	1.28	28	0	14	28.47	0.94	26	0.66	14
	#2	33.87	0.92	22	0	11	28.49	1.10	22	0	11
	#3	34.75	0.51	24	0	12	29.34	0.82	24	0	12
HGB (g/dL)	#1	11.85	0.47	28	0.32	14	10.09	0.68	28	0	14
	#2	11.96	0.56	22	0	11	10.24	0.43	22	0.21	11
	#3	12.15	0.58	24	0	12	10.35	0.61	24	0	12
PLT ($\times 10^9/L$)	#1	386.89	5.15	28	5.09	14	141.05	6.03	28	4.14	14
	#2	387.91	6.69	22	8.88	11	128.50	5.38	22	2.96	11
	#3	330.37	4.50	24	1.09	12	129.38	4.74	24	2.70	12
WBC ($\times 10^9/L$)	#1	9.55	9.07	28	6.70	14	19.06	9.05	28	0	14
	#2	7.36	7.24	22	4.31	11	16.09	4.75	22	6.15	11
	#3	7.69	8.11	24	2.78	12	15.51	5.47	24	3.83	12
GRAN ($\times 10^9/L$)	#1	6.15	9.30	28	5.76	14	10.29	8.28	28	0	14
	#2	4.67	8.58	22	7.33	11	8.01	3.66	22	4.08	11
	#3	4.94	8.39	24	3.61	12	8.27	4.73	24	3.18	12
LYMPH/MONO ($\times 10^9/L$)	#1	3.40	12.05	28	8.95	14	8.77	11.32	28	0	14
	#2	2.68	7.60	22	8.21	11	8.07	6.53	22	8.71	11
	#3	2.74	11.86	24	4.13	12	7.24	9.09	24	5.49	12

Key to QBC Control Precision Table:

Intra-run precision = variability between duplicate tubes during the same run.

Inter-run precision = variability between two runs per day over multiple days.

df = degrees of freedom

0 = negative estimate (variance was negative)

Site #1 & Site #2 = POLs

Site #3 = BDPCD

7.4.2 Accuracy

The performance of AccuTubes with the QBC Autoread Plus system is based on data from venous blood samples collected in Vacutainer™ brand collection tubes containing K₃EDTA anticoagulant. Venous blood samples provide a more stable test system than capillary blood for comparing results from multiple methods. While skin puncture samples provide clinically relevant results, they are subject to more variation due to the nature of the sampling technique.

Approximately 290 blood samples were analyzed on both the QBC Autoread Plus System with AccuTubes and Coulter™ Hematology analyzers (S Plus, S Plus IV, STKS, STKR)*. The correlation coefficients for the WBC, Gran, L/M, HCT, and HB parameters were 0.95 or greater. The correlation coefficient for the PLT parameter was 0.93. Complete statistical results are presented below.

*Products of Coulter Electronics,
Hialeah, FL

Parameter	Correlation Coefficient	Slope	Intercept	QBC Mean	Cell Counter Mean	Range of Values	Number of Samples
Hematocrit (%)	0.993	0.960	2.587	35.7	34.5	13.8 - 60.2	294
Hemoglobin (g/dL)	0.994	0.992	0.050	11.7	11.7	5.5 - 19.0	293
Platelet (× 10 ⁹ /L)	0.931	0.926	16.463	267	271	29 - 843	278
WBC (× 10 ⁹ /L)	0.978	1.045	-0.239	10.8	10.5	2.1 - 81.5	282
Granulocyte (× 10 ⁹ /L)	0.985	1.071	-0.458	7.9	7.8	0.7 - 71.0	277
Lymph/Mono (× 10 ⁹ /L)	0.957	0.826	0.614	2.9	2.8	0.2 - 76.9	280

*Products of Coulter Electronics, Hialeah, FL

The hematocrit results shown above reflect the calibration methods of the Coulter analyzers used in the correlation study. The QBC Autoread Plus software has been calibrated to match the international reference standard for microhematocrit

(MHCT) technology.¹³ The data shown in the table below were obtained by comparing the QBC Autoread Plus/AccuTube results against the microhematocrit reference method.

Parameter	Correlation Coefficient	Slope	Intercept	QBC Mean	Cell Counter Mean	Range of Values	Number of Samples
Hematocrit (%)	0.996	1.003	-0.111	34.4	34.4	17.5 - 53.1	120

Section 8 Bibliography

1. Wintrobe, M.M. (1981) *Clinical Hematology*, 8th Ed., Lea & Febiger, Phila., PA.
2. Wintrobe, M.M. (1933) "Macroscopic Examination of the Blood," *American Journal of Medicine*, SC., 185:58-71.
3. Olef, I. (1937) "The Determination of Platelet Volume," *Journal of Laboratory and Clinical Medicine*, 23:166-178.
4. Bessis, M. (1940) "Une méthode permettant l'isolement des différents éléments figurés du sang," *Sang*, 14:262.
5. Davidson, E. (1960) "The Distribution of the Cells in the Buffy Layer in Chronic Myeloid Leukemia," *Acta haemat.*, 23:22-28.
6. Zucker, R.M. and Casse, B. (1966) "The Separation of Normal Human Leukocytes by Density and Classification by Size," *Blood*, 34:5,591-600.
7. Jackson, J.F. (1961) "Supravital Blood Studies, Using Acridine Orange Fluorescence," *Blood*, 17:643-17:643-649.
8. Wardlaw, S.C. and Levine, R.A. (1983) "Quantitative Buffy Coat Analysis," *JAMA*, 5:617-620.
9. Data on file ay QBC Diagnostics, Inc., Port Matilda, PA 16866.
10. Young, D.S., Pestaner, L.C. and Gibberman, V. (1975) "Effects of Drugs on Clinical Laboratory Tests," *Clinical Chemistry*, 21, 313D, 3454D, 346D, 390D, 391D, 392D.
11. Elking, M.P. and Kabat, H. (1968) "Drug Induced Modifications of Laboratory Test Values," *American Journal of Hospital Pharmaceuticals*, 25,485.
12. Williams, W.J., Beutler, E., Lichtman, M.A., Coller, B.S., Kipps, T.J., Ed. *Hematology*, 5th Ed., New York: McGraw Hill Co., 1995, p. 9.
13. National Committee for Clinical Laboratory Standards: Approved Standard H7-A (1985) "Procedure for Determining Packed Cell Volume by the Microhematocrit Method."
14. National Committee for Clinical Laboratory Standards (NCCLS): Approved Standard H15-A (1985) "Reference Procedure for Quantitative Determination of Hemoglobin in Blood."

Test Procedures for QBC Venous and Capillary Tubes

Appendix A-1

A-1.1 MATERIALS PROVIDED

The QBC Autoread Plus Hematology System consists of the following instruments and accessories with which to perform hematology tests:

- QBC Autoread Plus Analyzer with software cartridge
- QBC Power Pack
- QBC Capillary Centrifuge
- Printer
- Calibration Check Rod
- Workstation
- Forceps
- QBC Pipetter

A-1.2 MATERIALS REQUIRED BUT NOT PROVIDED

A-1.2.1 QBC Tubes for Hematology Tests

The following disposables are available for QBC Hematology tests:

- QBC Venous Tubes
 - 100 Tests 424240
 - 1000 Tests 424237
- QBC Capillary Tubes
 - 100 Tests 424241
 - 1000 Tests 424238

A-1.3 HEMATOLOGY TEST PROCEDURES

- Be sure QBC blood tubes have not exceeded their labeled expiration date or open vial stability.
- Maintain laboratory temperature at 68° to 90°F (20° to 32°C).
- Venous blood: specimen must be well-mixed and at room temperature. For a valid platelet count, blood must be less than 90 minutes old.
- Capillary blood: collect only from free-flowing finger puncture or plantar surface of heel in infants less than one year old.

Interfering Substances

- Hemolysis: Do not perform tests on visibly hemolyzed blood specimens.
- Bilirubin: No effects on test results have been observed at bilirubin concentrations up to 8.5 mg/dL.⁹
- Coumadin: Anticoagulant therapy has been

shown to have no clinically significant effect on performance.⁹

- Doxorubicin: Treatment with the anthracyclenic drug Doxorubicin does not appear to interfere with the QBC test method.⁹
- Drugs: The effects of other potentially interfering drugs and their metabolites on QBC tests have not been established.^{10,11}

Specimen Storage and Stability

After collection, anticoagulated venous blood may be held in the collection tube at room temperature 68° to 90°F (20° to 32°C) for the times indicated below.

- Up to **90 minutes** from blood collection, provided all parameters – *including the platelet count* – are required. Specimens more than 90 minutes old may yield falsely elevated platelet counts. (Note: After centrifugation, QBC Tubes may be tested up to 4 hours later.)
- Up to **4 hours** from blood collection, provided all parameters – *except the platelet count* – are required. (Note: After centrifugation, QBC tubes may be tested up to 4 hours later.)

Filled QBC capillary-blood tubes should be mixed and centrifuged promptly after blood collection.

WARNING

Blood specimens may contain the Hepatitis B Virus (HBV), Hepatitis C Virus (HCV), Human Immunodeficiency Virus (HIV), or other disease-causing agents. Handle all patient specimens as potential biohazards capable of transmitting infection. Wear appropriate personal protective equipment, including gloves, when collecting and processing blood.

A-1.3.1 Procedures with Standard QBC Venous Tubes

(Note: Handling differences illustrated in the procedures that follow are due to differences between the 100-Test (p/n 424240) and 1000-Test (p/n 424237) QBC Venous Tube packaging.)

IMPORTANT: For directions on opening and closing the barrel of the QBC pipetter, refer to Section 4.8.

Step 1: Fill and Seal Blood Tube

With barrel in open position and pipetter horizontal, gently insert end of tube *nearest red lines* into QBC pipetter; close barrel by twisting backward. Depress plunger of pipetter, then insert distal end of tube into specimen of well-mixed anticoagulated venous blood (A). Smoothly but quickly release plunger of pipetter to fill tube. With tube horizontal, check that blood level is within ± 1 mm of black fill line. Carefully wipe outside surface of tube with lint-free tissue.

With 424240 Tray – Press distal end of tube firmly into closure in tube tray (B1). Twist pipetter slightly to be sure that closure remains on tube when pipetter and tube are lifted. Open barrel of pipetter and remove tube.

or

With 424237 Box – Remove closure from test box. Press distal end of blood tube into closure (B2). Twist pipetter slightly to be sure that closure remains on tube. Open barrel of pipetter and remove tube.

Manually twist and firmly push on closure to form leak-tight seal (see C next page). Be sure closure is completely seated and properly aligned. **Failure to align and seat closure properly may result in blurred interfaces.**

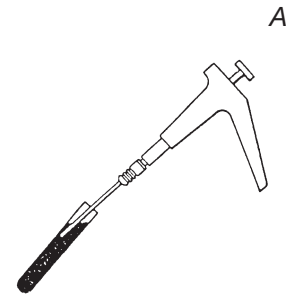

B1
With 424240 Tray

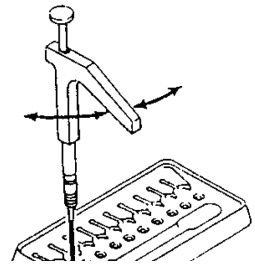

or

B2
With 424237 Box

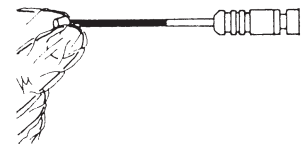

CAUTION

**Do not force closure onto tube.
Tube is made of glass and may break.**

Step 2: Roll Tube Between Fingers to Mix

Gently roll tube between fingers *at least 10 times* or *for at least 5 seconds*, keeping unsealed end slightly above horizontal (D). **Proceed promptly to Step 3.**

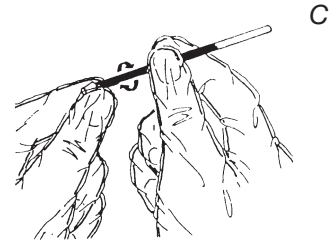

Step 3: Insert Float

With 424240 Tray – Slide unsealed end of tube over tip of pre-positioned float (E1) and push until float is inside tube as far as possible. Gently lift closure end of tube until float releases from its tray slot. Raise unsealed end of tube slightly above horizontal to prevent float from falling out. If necessary, press end of float against clean surface until float is inside tube. **NOTE: Never touch floats with fingers or gloves. Use forceps to handle loose or dropped floats.**

With 424237 Box – Using forceps supplied with analyzer, pick up float from well. Insert forceps-held float into unsealed end of tube (E2). With forceps, tap float into tube. **Never touch float with fingers or gloves.**

Note: After inserting float, tubes can be held for centrifuging provided they are stored vertically, closure down in workstation. A maximum of 15 minutes is allowable between insertion of float and centrifugation.

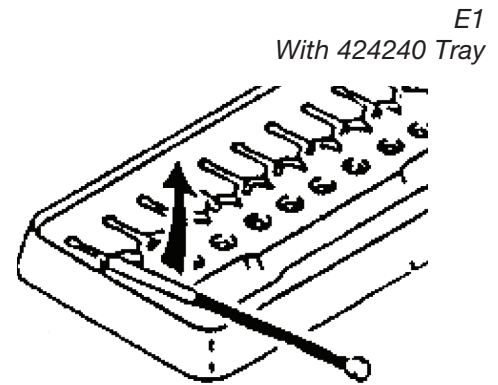
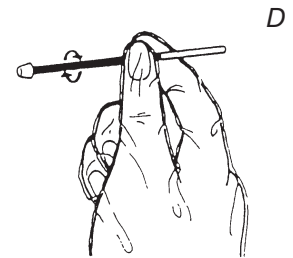

Step 4: Centrifuge for 5 Minutes

Place blood tubes in centrifuge. Spin down according to instructions in centrifuge manual. When centrifugation is complete, **promptly remove tubes.**

Time Delay Between Completion of Centrifugation and Tube Reading: Centrifuged QBC tubes are stable for up to 4 hours prior to reading, if stored vertically (closure down) in workstation, away from heat and intense light.

IMPORTANT:

- **Excessive heat may disturb cell interfaces in centrifuged blood tube. Avoid picking up or handling spun tube below plasma column. Do not place centrifuged tubes on warm surfaces or under intense light.**
- **Do not leave blood tubes on rotor after centrifugation. Remove and read immediately, or temporarily store in vertical, closure-down position.**
- **Do not twist or move tube closures after centrifugation.**

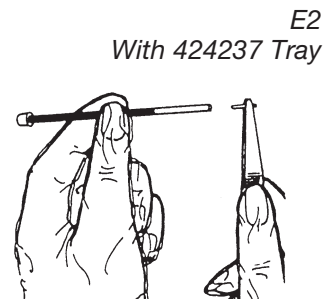

Step 5: Place Tube in Analyzer

Place centrifuged venous tube onto loading platform of Autoread Plus analyzer; select normal range of patient, if desired; then close platform door. ASSAY IN PROGRESS will appear on message display, followed by test sequence described in Section 4.2.2. Leave door closed until assay is completed and test results are displayed and printed. See Section 4.2.3.

Remove tube and insert next centrifuged QBC venous or capillary blood tube.

A-1.3.2 Procedures with Standard QBC Capillary Tubes

(Note: Handling differences illustrated in the procedures that follow are due to differences between the 100-Test (p/n 424241) and 1000-Test (p/n 424238) QBC Capillary Tube packaging.)

Step 1: Fill and Mix Tube

From end of capillary-blood tube *nearest two black lines*, fill tube with finger puncture blood* to any level *between* black lines (A). With lint-free tissue wipe off any blood on outside of tube, being careful not to draw specimen from tip of the tube.

* Blood may be from plantar surface of heel in infants less than one year old.

Keeping tube nearly horizontal, roll tube between fingers several times to mix blood with anticoagulant coating (B).

WARNING

Blood specimens may contain the Hepatitis B Virus (HBV), Hepatitis C Virus (HCV), Human Immunodeficiency Virus (HIV), or other disease-causing agents. Handle all patient specimens as potential biohazards capable of transmitting infection. Wear appropriate personal protective equipment, including gloves, when collecting and processing blood.

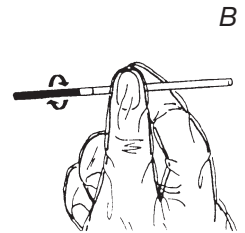
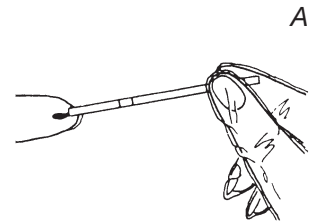

Turn tube around and tilt, allowing blood to flow to opposite end of tube (C). Roll tube between fingers at least 10 times or for at least 5 seconds to mix blood with potassium oxalate and acridine orange coating. **Promptly proceed to Step 2.**

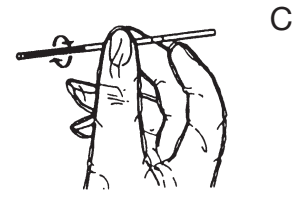

Step 2: Seal Tube and Insert Float

With 424241 Tray – Place gloved index finger over end of tube nearest fill lines, and insert distal end into closure in tube tray (D1).



With 424238 Box – Place gloved index finger over end of tube nearest fill lines. Remove closure from test tray well and press distal end of tube onto closure (D2).

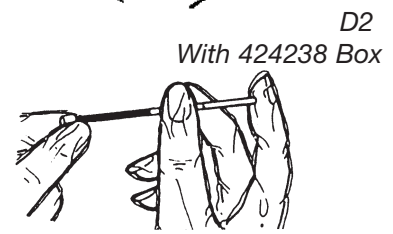

Manually twist and firmly push on closure to form leak-tight seal (E). Be sure closure is completely seated and properly aligned. **Failure to align and seat closure properly may result in blurred interfaces.**

CAUTION

**Do not force closure onto tube.
Tube is made of glass and may break.**

With 424241 Tray – Slide unsealed end of tube over tip of pre-positioned float (F1) and push until float is inside tube. Gently lift closure end of tube until float releases from its tray slot. Raise unsealed end of tube slightly above horizontal to prevent float from falling out. If necessary, press float against clean surface to push end into tube. **NOTE: Never touch float with fingers or gloves. Use the forceps to handle loose or dropped floats.**

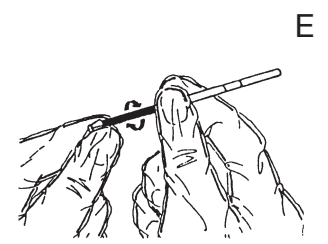

With 424238 Box – Using forceps supplied with analyzer, pick up float from test tray well. Insert forceps-held float into unsealed end of tube (F2). With forceps, tap float into tube. **Never touch float with fingers.**

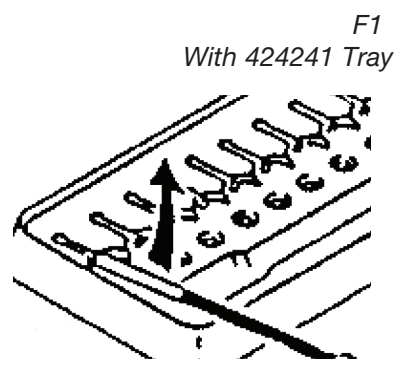

Note: After inserting float, tubes can be held for centrifuging provided they are stored vertically, closure down in workstation. A maximum of 15 minutes is allowable between insertion of float and centrifugation.

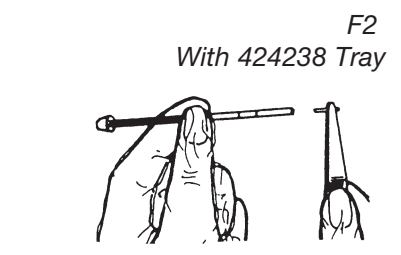

Step 3: Centrifuge for 5 Minutes

Place blood tubes in QBC Capillary Centrifuge. Spin down according to instructions in centrifuge manual. When centrifugation is complete, **promptly remove tubes.**

Time Delay Between Completion of Centrifugation and Tube Reading: Centrifuged QBC tubes are stable for up to 4 hours prior to reading if stored vertically (closure down) in workstation, away from heat and intense light.

IMPORTANT:

- **Excessive heat may disturb cell interfaces in centrifuged blood tube. Avoid picking up or handling spun tube below plasma column. Do not place centrifuged tubes on warm surfaces or under intense light.**
- **Do not leave blood tubes on rotor after centrifugation. Remove and read immediately, or temporarily store in vertical, closure-down position.**
- **Do not twist or move tube closures after centrifugation.**

Step 4: Place Tube in Analyzer

Place centrifuged capillary tube onto loading platform of Autoread Plus analyzer; select normal range of patient, if desired; close platform door. ASSAY IN PROGRESS will appear on message display followed by test sequence described in Section 4.2.2. Leave door closed until assay is completed and test results are displayed and printed. See Section 4.2.3.

Remove tube and insert next centrifuged QBC venous or capillary blood tube.

WARNING

Blood specimens may contain the Hepatitis B Virus (HBV), Hepatitis C Virus (HCV), Human Immunodeficiency Virus (HIV), or other disease-causing agents. Handle all patient specimens as potential biohazards capable of transmitting infection. Wear appropriate personal protective equipment, including gloves, when collecting and processing blood.

A-1.4 CALIBRATION DETAILS

Perform the calibration check described in Section 4 of this manual. Before running patient samples, daily testing of the Autoread Plus analyzer calibration check rod is strongly recommended to verify the performance of the instrument. Calibration adjustments must be made only by authorized service personnel.

A-1.5 QUALITY CONTROLS

A-1.5.1 QBC Hematology Tests

Controls and proficiency tests to monitor performance are described in 4.5.2 and 4.5.3.

Reference methods for QBC hematology tests are provided below.

Parameter	Reference Method
Hematocrit.....	Centrifugal Microhematocrit ¹³
Hemoglobin	Cyanmethemoglobin Method ¹⁴
WBC	Impedance Cell Counter
GRANS	100-Cell Manual Differential Count*
LYMPH/MONO.....	100-Cell Manual Differential Count**
PLT.....	Phase Microscopy or Impedance Cell Counter
MCHC.....	***

*Manual differential count of granulocytes should include the sum of neutrophils, eosinophils, and basophils for comparison with the GRANS count of Autoread Plus analyzer.

**Manual differential count should include the sum of lymphocytes and monocytes for comparison with the LYMPH/MONO count of Autoread Plus analyzer.

***MCHC of the Autoread Plus analyzer is a calculated value derived from the hematocrit and hemoglobin. Comparison of these latter parameters with the recommended reference methods will ensure accuracy of MCHC.

A-2.1 TEST RESULTS

A-2.1.1 Digit-Decimal Format

Test values generated by the QBC Autoread Plus analyzer are displayed in the following units and decimal formats:

- Hematocrit, % XX.X
- Hemoglobin, g/dL XX.X
- MCHC*, g/dL XX.X
- Platelet Count (PLT), 10⁹/L XXX
- White Cell Count (WBC), 10⁹/L XX.X
- GRANS (abs.), 10⁹/L XX.X
- GRANS (rel.), % XX
- LYMPH/MONO (abs.), 10⁹/L XX.X
- LYMPH/MONO (rel.), % XX

* Mean Corpuscular Hemoglobin Concentration. MCHC in grams per deciliter of red cells (g/dL) is equal to MCHC percent (%).

To convert hemoglobin to millimoles per liter, multiply the value in g/dL by 0.6206 to obtain hemoglobin in mmol/L.

When testing whole blood, irregularities detected in length measurement or computed values will cause the analyzer to display an error flag; in certain cases the test may be aborted and no results or only partial results will be displayed.

A-2.1.2 Operating Ranges

The blood parameters measured by the QBC Autoread Plus analyzer have been validated over the following range of values for QBC standard tubes:

- Hematocrit 25 - 55%
- Hemoglobin 5.0 - 20.0 g/dL
- MCHC 25.0 - 37.3 g/dL
- Platelet Count 80 - 600 (× 10⁹/L)
- White Cell Count 2.0 - 30.0 (× 10⁹/L)
- Grans 1 - 99%; 0.5 - 29.7 × 10⁹/L (over a WBC of 2.0 - 30.0 × 10⁹/L)
- Lymph/Mono 1 - 99%; 0.5 - 29.7 × 10⁹/L (over a WBC of 2.0 - 30.0 × 10⁹/L)

If the specimen yields test values outside these ranges, confirmation by other methods is recommended. On the display of the analyzer, test results falling outside the above ranges will flash off and on.

A-2.2 TEST LIMITATIONS

Quality medical care requires that laboratory values be correlated with each patient's symptoms and signs by a trained practitioner.

Section A-2.1.2 lists the validated upper and lower limits of the operating range. Values above and below these validated ranges should be confirmed by an alternate method.

Test values cannot be derived by the Autoread Plus analyzer unless distinct cell layers with well-defined interfaces form in the blood tube. Non-separation or cell "streaming" can occur under certain hematologic or pathologic conditions, e.g., when an orange-yellow layer of granulocytes fails to form in the QBC tube, or when the lower boundary of granulocytes is so poorly defined that the instrument cannot detect a clear interface. The condition is generally the result of a shift in red-cell specific gravity toward that of the granulocytic leukocytes, causing the red cells and granulocytes to intermingle.

Studies indicate that the frequency of unreadable QBC tubes among ambulatory office patients of the general practitioner should average less than 1%. Among clinical out-patients and hospital patients, the frequency of unreadable tubes may range from 1.5% to 10%, depending on the pathologies of the patient group.⁹

User errors in processing or use of outdated or inappropriately stored tubes can also result in non-reported results. Practitioners must not assume that unreported values are normal; further testing with an alternative method is essential.

Automated granulocyte and lymphocyte/monocyte differential counts cannot replace the conventional manual differential. Due to grouping by density of the cell populations by the QBC system method, the system cannot discriminate between normal and abnormal cell types in disease states characterized by the presence of abnormal white cell types or nucleated red blood cells. If abnormal cell populations are suspected, verification of QBC test results or testing and diagnosis by alternative methods is essential.

The combined lymphocyte/monocyte count should not be used to test for lymphocytopenia in evaluating patients with known or possible immunodeficiencies. Further evaluation of lymphocyte/monocyte counts in relevant situations must include a manual differential and lymphocyte subset analysis.

A-2.3 EXPECTED VALUES

The following table provides normal ranges reported in the literature.^{1,12} Offices or laboratories may choose to develop normal hematology ranges based on the characteristics of their patient population.

Parameter	Range
Hematocrit Males (%)	42-50
Hematocrit Females (%)	36-45
Hemoglobin Males (g/dL)	14-18
Hemoglobin Females (g/dL)	12-16
MCHC (g/dL)	31.7-36.0
Platelet Count ($\times 10^9/L$)	140-440
WBC ($\times 10^9/L$)	4.3-10.0
Granulocyte Count ($\times 10^9/L$)	1.8-7.2
Lymphocyte/Monocyte Count ($\times 10^9/L$)	1.7-4.9

A-2.4 SPECIFIC PERFORMANCE CHARACTERISTICS

A-2.4.1 Precision

Data on within-run reproducibility of the QBC Autoread Plus System from five blood specimens with QBC venous tubes and five blood specimens with QBC capillary tubes are shown in Table A-2-1. The

means and % C.V.'s below are based on replicate tests of 10 tubes per sample; e.g., for Sample 1, n=10, etc.

*Table A-2-1
WITHIN-RUN PRECISION, QBC AUTOREAD PLUS SYSTEM⁹*

QBC VENOUS BLOOD TUBES									
N = 10 per sample	HCT	HB	MCHC	PLT	WBC	#GRANS	%GRANS	#L/M	%L/M
SAMPLE 1									
MEAN	47.6	15.9	33.5	155	7.1	4.6	65	2.5	35
% CV	1.87	0.74	2.17	8.91	3.16	2.71	2.02	5.86	3.78
SAMPLE 2									
MEAN	23.1	7.4	31.8	288	6.7	4.9	73	1.8	27
% CV	1.44	0.66	1.22	3.27	2.33	3.07	1.41	3.69	3.85
SAMPLE 3									
MEAN	31.9	10.4	32.5	550	11.2	7.9	71	3.3	29
% CV	1.5	1.27	1.29	3.59	5.41	7.3	2.86	6.49	6.96
SAMPLE 4									
MEAN	52.3	16.3	31.1	745	16.1	10.6	66	5.6	34
% CV	1.4	1.35	0.96	4.68	6.42	5.86	1.43	8.09	2.77
SAMPLE 5									
MEAN	41.6	13.6	32.8	91	5.3	3.6	68	1.7	32
% CV	1.73	1.45	0.8	5.34	6.72	6.2	1.85	9.02	4
QBC CAPILLARY BLOOD TUBES									
N = 10 per sample	HCT	HB	MCHC	PLT	WBC	#GRANS	%GRANS	#L/M	%L/M
SAMPLE 1									
MEAN	49.1	15.3	31.2	144	8.4	5.9	70	2.5	30
% CV	1.1	0.9	0.9	13.1	6.7	10.1	4.3	7.4	10.2
SAMPLE 2									
MEAN	31.9	9.7	30.3	522	11.6	8.1	70	3.5	30
% CV	2.0	1.1	1.7	3.7	4.5	4.1	1.1	6.1	2.6
SAMPLE 3									
MEAN	54.9	16.4	29.9	582	15.6	10.3	66	5.4	34
% CV	0.9	1.2	1.0	6.6	2.8	2.9	2.7	7.0	5.2
SAMPLE 4									
MEAN	42.8	12.9	30.2	88	5.7	3.8	66	2	34
% CV	0.8	0.7	0.6	9.9	5.6	5.0	2.7	9.4	5.3
SAMPLE 5									
MEAN	40.8	12.5	30.7	197	5.9	3.9	67	2	33
% CV	1.9	1.5	1.1	8.3	7.5	9.0	1.7	4.2	3.5

A-2.4.2 Accuracy

Performance of the Autoread Plus analyzer with QBC standard tubes is typical of the family of QBC hematology analyzers exhibiting the performance shown in Table A-2-2 below.

Table A-2-2

CORRELATION DATA: QBC SYSTEM HCT, HB, PLT, AND WBC						
Parameter	Specimen (Reference Method)	n=	Range of Reference Values	Correlation Coefficient	Slope	Intercept
HCT (%)	Venous (Microhematocrit) ¹³	200	16.5 - 56.6	0.9884	0.9952	-0.3655
	Capillary (Microhematocrit) ¹³	100	34.0 - 50.7	0.9450	1.0000	0.0027
HB (g/dl)	Venous (Cyanmethemoglobin) ¹⁴	206	7.0 - 17.8	0.9905	1.0007	-0.0477
	Capillary (Cyanmethemoglobin) ¹⁴	112	10.1 - 18.2	0.9590	0.9888	-0.05077
PLT (× 10 ⁹ /l)	Venous (See Note 1)	492	9 - 733	0.9056	0.9744	-8.2440
	Venous (Phase Microscopy)	101	2 - 869	0.9326	1.0260	-0.0583
	Capillary (UF-100)	99	146 - 383	0.7129	0.9903	0.1430
WBC (× 10 ⁹ /l)	Venous (See Note 2)	385	1.8 - 32.0	0.9825	0.9613	0.5059
	Capillary (Coulter ZBI)	100	3.9 - 12.7	0.8652	0.9870	-0.0592

Notes to Table A-2-2:

1. Reference methods – ULTRA-FLO 100 Platelet analyzer and Coulter Model S+ analyzer
2. Reference methods – Coulter ZBI analyzer and Coulter Model S+ analyzer

The MCHC value displayed by the Autoread Plus analyzer is electronically calculated from the hemoglobin and hematocrit by the standard formula of derivation. MCHC was compared with values obtained by a Coulter analyzer and a manual method as reference. The correlation study involved 196 venous specimens. Due to the numerically narrow range of the MCHC parameter, neither of the automated test procedures (QBC analyzer or Coulter analyzer) correlated perfectly with the reference method; however, MCHC by the QBC analyzer correlated as well with the reference method as the Coulter analyzer (Table A-2-3).

Table A-2-3

CORRELATION MATRIX: MCHC (196 Specimens)			
	QBC	Coulter	Reference
QBC	1.0		
Coulter	0.6762	1.0	
Reference	0.6727	0.6859	1.0

Appendix B

Service, Maintenance and Specifications

B-1 INTRODUCTION

Service and maintenance procedures for the QBC Autoread Plus System approved for use by the customer are limited to the items described in this Appendix. DO NOT ATTEMPT ANY OTHER SERVICE OR REPAIRS. Appendix C contains a list of replacement parts and accessories available through your QBC distributor.

For technical assistance in the United States, call:

QBC Diagnostics Inc. Technical Service
1-866-265-1486 (toll free)

Outside the United States, call: +1-814-692-7661
or contact your distributor or nearest QBC
Diagnostics Inc. office.

B-2 SERVICE AND MAINTENANCE

B.2.1 Autoread Plus Analyzer

There are no customer-serviceable parts on the Autoread Plus analyzer. Calibration adjustments, failure of internal lamps, or mechanical-electrical problems must be referred to a qualified QBC Diagnostics Inc. service technician.

B.2.2 Power Pack

There are no customer-serviceable parts on the power pack. The unit, however, is protected by internal overload and thermal fuses. If the power pack fails to supply d.c. outputs to the analyzer, check the electrical line to the receptacle that supplies current to the power pack before requesting service.

B.2.3 QBC Capillary Centrifuge

The operator's manual supplied with the QBC Capillary Centrifuge contains detailed instructions and procedures for performing operator-authorized service and repairs.

B.2.4 QBC Pipetter

Blood leakage or failure of the QBC pipetter to aspirate blood to the correct level may indicate that the pipetter barrel mechanism is worn and should be replaced. Replacement barrels (Part No. 421705) can be ordered through your distributor.

B-3 SPECIFICATIONS

B-3.1 Autoread Plus Analyzer (p/n 429576)

Electrical Inputs	±16.5 VDC, ±12.5 VDC, ±20 VDC (Refer to diagram in Figure 3-13, Section 3)
Display	Reflective-type Liquid crystal
Operating Temp. (with QBC Tubes)	68 °F to 98 °F (20 °C to 32 °C)
(with AccuTube)	68 °F to 98 °F (20 °C to 37 °C).
Non-Operating Storage Temp.	-4 °F to +140 °F (-20 °C to +60 °C)
Humidity	10% to 95% (non-condensing)
Weight	8 lbs. (3.6 kg)
Dimensions	W 13.5" x D 9.5" x H 4" (34 cm x 24 cm x 10 cm)

B-3.2 Power Pack (p/n 424590)

Voltage	90-265 VAC
Frequency	50-60 Hz
Power	170 W
Power Cord	8 ft. (2.4 m) Grounded cord and plug
DC Output Cord	3 ft. (0.3 m) 8 wire, shielded cord 9-pin male plug
Weight	5.5 lbs. (2.5 kg)
Dimensions	W 7" x D 3.75" x H 3.5" (17.8 cm x 9.5 cm x 8.9 cm)

B-3.3 QBC Capillary Centrifuge (p/n 424740)

Nominal Speed	12,000 rpm ±80 rpm
Relative Centrifugal Force (RCF)	14,387 × g (at nominal speed)
Rotor Capacity	20 QBC blood tubes; numbered tube slots
Timer	Electronic 300 seconds spin 15-20 seconds deceleration
Non-Operating Storage Temp.	-15 °F to +150 °F (-26 °C to +66 °C)
Input	90-264 VAC, 47-63 Hz
Output	47 ±3 VDC 3 ADC Maximum, steady state

*See QBC Capillary Centrifuge Operator's Manual for complete data.

Appendix C

List of Parts – QBC Autoread Plus System

DISPOSABLE BLOOD TUBES	Order No.
QBC AccuTubes	
100 Tests	423406
QBC Venous Tubes	
100 Tests	424240
1000 Tests	424237
QBC Capillary Tubes	
100 Tests	424241
1000 Tests	424238
 CONSUMABLES AND ACCESSORIES	
Hematology Controls	424304
Extended Range Controls	424305
1.8 mm Blade Lancets	420000
2.3 mm Blade Lancets	420001
 REPLACEMENT PARTS	
Autoread Plus Analyzer (w/ Accessories)	429577
Autoread Plus Analyzer (No Accessories)	429576
QBC Capillary Centrifuge	425740
USB Cable	421550
Calibration Check Rod	424613
QBC Workstation	424226
QBC Pipetter	424225
Pipetter Barrel	421705
QBC AccuTube Pipetter Spacer	421706
QBC Autoread Plus Operator's Manual (English)	424593
QBC Autoread Plus Analyzer Software Cartridge	421923
QBC Autoread Plus Analyzer Power Pack	424590
QBC Capillary Centrifuge Power Pack	421763
QBC Line Cord (USA)	421634
QBC Line Cord (UK)	421554
QBC Line Cord (Europe)	421551
QBC Capillary Centrifuge Cover Assembly	421291
QBC Capillary Centrifuge Rotor Cover Access Knob	421317

Appendix D Warranty

QBC Diagnostics Inc. warrants the QBC Autoread Plus System to be free from defects in workmanship and materials for a period of one (1) year from the date of installation, provided the System is operated in accordance with the QBC Autoread Plus System Manual. During such period, QBC Diagnostics Inc. agrees to replace or repair any parts which, in its sole judgment, are found to be defective, provided the System has not been subjected to misuse or abuse. The warranty stated herein shall extend to the original consumer only and not to any subsequent consumer of the System.

QBC Diagnostics Inc. shall not be liable for any incidental or consequential damages. QBC Diagnostics Inc. makes no other warranties, expressed or implied, except as stated herein.
