

MODEL 708B

Laboratory Centrifuge

OPERATION MANUAL



THE DRUCKER CO.

Reliability in Laboratory Centrifuges Since 1932

200 Shady Lane

Philipsburg, PA. 16866

TEL: (814) 342-6205 FAX: (814) 342-6211

On the web at www.druckercompany.com



Introduction:

Centrifuges are an essential instrument in the laboratory preparation process and **The Drucker Company** has been *manufacturing centrifuges since 1932*.

The company was formed in St. Louis, Missouri, when Ken Drucker purchased the Phillips Company, an instrument repair company established in 1908. Within a few years, Mr. Drucker had turned the firm's business into that of a manufacturer of centrifuges. A man of foresight, Drucker began experimenting with instruments far in advance of his day, and in time became a respected figure in his industry. His concepts and ideas were so advanced that they are being used today in centrifuge design and operation.

We at **The Drucker Company** are proud of this long history of centrifuge manufacture. Today, as then, centrifuges continue to be the mainstay of the Company's business.

Sincerely,

Ken Moscone
President, The Drucker Co.



TABLE OF CONTENTS

<u>Section</u>	<u>Contents</u>	<u>Page</u>
<u>1.0</u>	CENTRIFUGE DESCRIPTION	5
1.1	Intended Use	5
1.2	Features	5
1.3	Construction.....	5
<u>2.0</u>	SPECIFICATIONS	6
<u>3.0</u>	SUPPLIED EQUIPMENT	6
<u>4.0</u>	INSTALLATION	8
4.1	External Packaging and Inspection.....	8
4.2	Setup Procedure	8
4.3	Power On Safety Check	8
4.4	Electric Brake Check	8
<u>5.0</u>	PROPER BALANCING	11
<u>6.0</u>	SERVICE.....	12
6.1	Drucker Service Philosophy	12
6.2	Motor Brush Replacement	12
6.3	Troubleshooting	12
<u>7.0</u>	MAINTENANCE.....	16
7.1	Centrifuge Cleaning.....	16
7.2	Accessory Cleaning	16
<u>8.0</u>	VERIFICATION/CALIBRATION.....	17
8.1	Speed Verification/Calibration.....	17
8.2	Time Verification/Calibration	17
<u>9.0</u>	RELATIVE CENTRIFUGAL FORCE.....	19
<u>10.0</u>	WARRANTY INFORMATION.....	20
10.1	Dealer Obligation Under Warranty	20
10.2	Disclaimer and Exclusions	20

LIST OF TABLES

TABLE	CONTENTS	PAGE
6.1	Troubleshooting	13 to 15

LIST OF FIGURES

FIGURE	TITLE	PAGE
1	Front View of Centrifuge	7
2A	Control Panel; Front View	9
2B	Control Panel; Rear View	10
3	DC Control Board	18
4	Relative Centrifugal Force Graph	19

REVISION STATUS

Issue: Number 5 Date: 6/18/2001 Initial Issue: February, 1995

Amended Pages: Replaced all photos, describe calibration of the new DC control board

Major Update: Yes

1.0 DESCRIPTION

1.1 Intended Use

The Drucker model 708B is a high-performance, medium capacity, laboratory centrifuge capable of separating the suspended media from (20) fluid samples contained in test tubes ranging from 3.5mL to 15mL.

1.2 Features

Important features of the Model 708 centrifuge include the following:

- . Timed operation from 1 to 30 minutes.
- . Variable speed from 500 to 4,000 RPM.
- . Dynamic electric braking.
- . Heavy gauge steel construction for safety and durability.
- . Transparent polycarbonate lid for safe observation of samples and optical

calibration of speed.

1.3 Construction (see Figures 1, 2A and 2B)

The Model 708B is constructed out of formed and welded steel panels for maximum strength and durability. Steel thickness is 0.075 inches. The 1/3 HP, brush type DC motor is attached to the centrifuge at its top by a molded rubber collar and is supported at its base by a floating bracket. This unique mounting allows the 708B motor to swing during operation thereby reducing noise and vibration. The motor bearings are the shielded, anti-friction type that never need lubrication. The lid of the 708B is machined out of a high strength polycarbonate plastic and is attached by two friction type nylon hinges. The hinges will hold the lid in any open position. The lid is mechanically secured to the cabinet by a molded polycarbonate latch that grips the underside of the top opening. The lid has a series of air inlet holes to provide for cooling of the samples. The base of the centrifuge is covered by a steel plate with louvers provided for air exhaust. The line cord and a fuse holder containing a 4 Amp. slow blow fuse are located at the rear of the centrifuge. The centrifuge rests on (4) rubber feet.

A formed steel control panel is attached to the front of the centrifuge. Mounted to the rear of the control panel are the mechanical timer, speed control potentiometer, electric brake switch, and speed control PC board. The PC board is connected to the motor through a connector block and is mounted on a steel mounting tray. The mounting tray, in turn, is attached to the control panel. The control panel assembly is attached to the centrifuge body by (4) machine screws; (2) on the side and (2) on the bottom, making removal of the control panel extremely quick and easy. The (20) place rotor is formed and machined out of 0.90 inch thick aluminum assuring long service, free for the concerns of fracture inherent in cast rotors.

NOTE: The electrical line cord provided with the 708B must be properly plugged into a power supply receptacle that is approved and is well grounded. The Model 708B operates on 115 volts AC at 60 Hz line frequency.

2.0 SPECIFICATIONS:

General specifications for the Model 708B Centrifuge

Maximum Speed (w/ loaded 20-place rotor)	4,000 RPM
Speed Range	500 to 4,000 RPM
Maximum Force (RCF) w/125 mm shields	2,200 xg
Maximum capacity	300 ml. (20 x 15ml)
Overall Dimensions	
Height with Lid Closed	13.0 in. (33.0 cm.)
Height with Cover Open	23.0 in. (58.4 cm.)
Outside Diameter	14.0 in. (38.1 cm.)
Inside Diameter	13.85 in. (38.1 cm.)
Centrifuge Motor	1/3 HP single phase
Protection Fuses	4 Amp. slow blow
Timer	Mechanical; 1 to 30 minutes
Power Requirements	115 VAC/60Hz
Weight - Including Rotor and (20) tube shields	37 lbs. (16.8 kg)

3.0 SUPPLIED EQUIPMENT:

The following items are supplied with each model 708B centrifuge:

1. One (1), twenty (20) place formed aluminum fixed angle rotor.
2. Twenty (20) tube shields
3. One (1) **Operator's Manual.**
4. One (1) **Test Sheet** identifying the Quality Control test results of the unit.

Model 708B Centrifuge

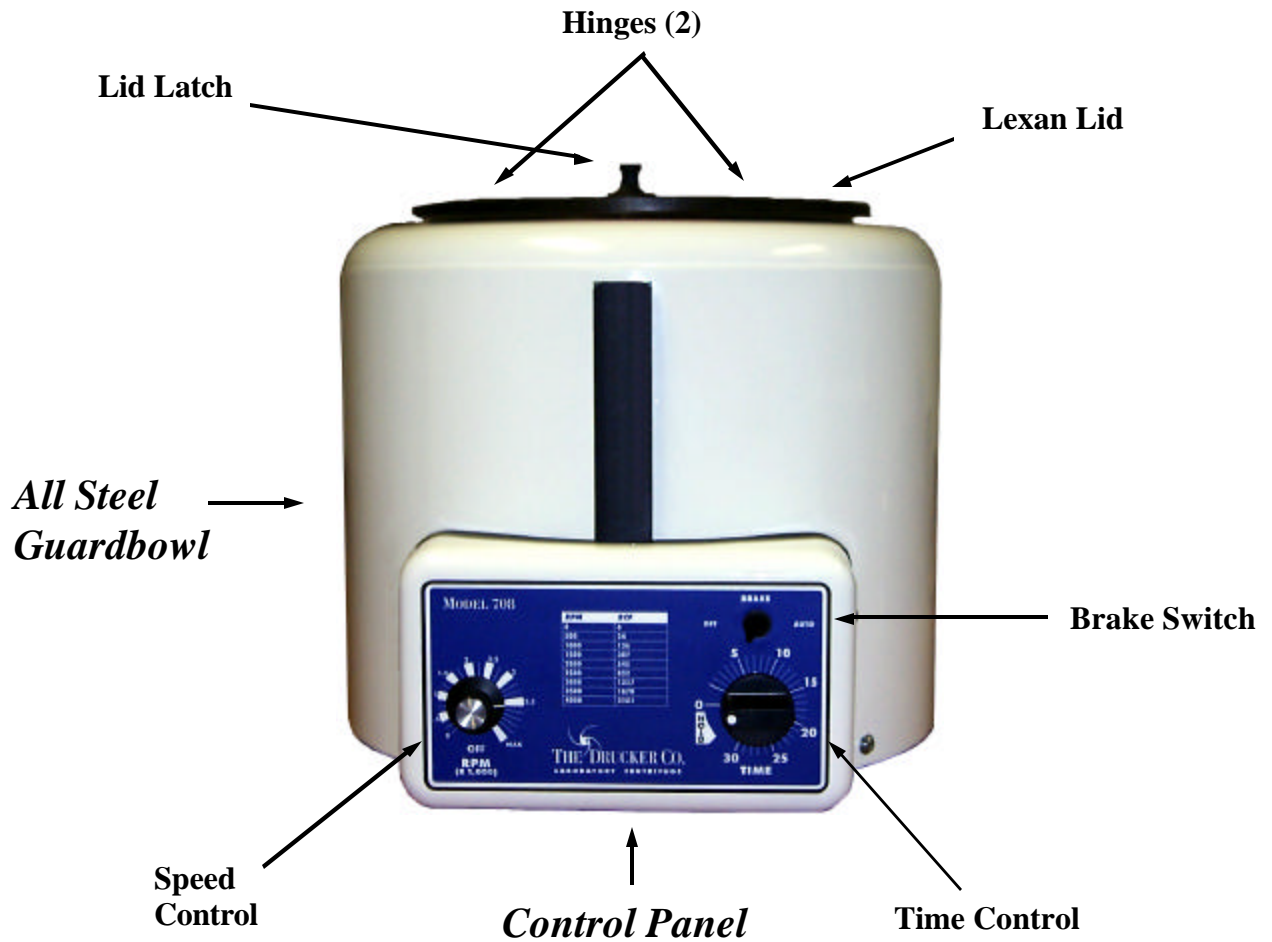

Figure 1.

4.0 INSTALLATION

4.1 External Packaging and Inspection

Carefully examine the centrifuge and document any damage that can be attributed to mishandling. A signed inspection report should be furnished by the shipping company. The Drucker Company is **Not Responsible** for transit damage.

4.2 Setup Procedure

- 1 Unpack the centrifuge and inspect for obvious damage; Place the centrifuge on a hard, stable surface.
- 2 **Note:** A benchtop clearance height of 23 inches (min.) is required to open the centrifuge lid.
Caution: *Failure to provide adequate space for ventilation can cause damage to the samples plus overheating and premature failure to the centrifuge.*
- 3 Unlatch and open the lid; remove the test tube shields and any protective shipping material from the guard bowl that may have been shipped inside the centrifuge..
- 4 Slowly rotate the rotor by hand; check for free and level rotation. **Caution:** *If the rotor wobbles or shows signs of uneven rotation, do not proceed. Contact your authorized dealer or The Drucker Company.*
- 5 Close and latch the lid. Verify that both the Timer and the Speed Control are in the "OFF" position. Plug the line cord into an approved electrical outlet. Proceed to section 4.3

4.3 Power On Safety Check (see Figure 2A):

- 1 Set the Brake Switch "On", the Speed Control for 2,000 RPM and the timer to (5) minutes.
- 2 The rotor should start spinning smoothly without any excessive noise;
- 3 Listen to the sound of the centrifuge; a smooth whirring sound should be heard. If there are any loud and unusual sounds, stop the centrifuge immediately **Do not proceed** ! Call your Authorized Dealer or the Drucker Company.
- 4 Let the time expire. If the timing cycle is correct and the centrifuge operates properly, insert the (20) test tube shields in the rotor. Repeat steps 4.3.1 to 4.3.3
- 5 If the centrifuge successfully passes steps 1-4 of this section proceed to section 4.4.

4.4 Electric Brake Check (see Figure 2A):

- 1 Repeat section 4.3.1. After the timer reaches "0" time and the power is cut to the motor the rotor should reach "0" RPM in 30 seconds (+/- 5 seconds).
- 2 Repeat section 4.3.1 but this time set the Brake Switch "Off". After the timer reaches "0" time and the power is cut to the motor the rotor should reach "0" RPM in approximately one minute and 30 seconds (+/- 20 seconds).

If the centrifuge successfully passes steps 1-4 of this section it is ready for operation.

Note: *The electric brake system is only activated when power is cut to the motor. If braking is desired the switch may set to "Auto" and left in that position without any adverse effect on the centrifuge.*

Model 708
Control Panel
Front View

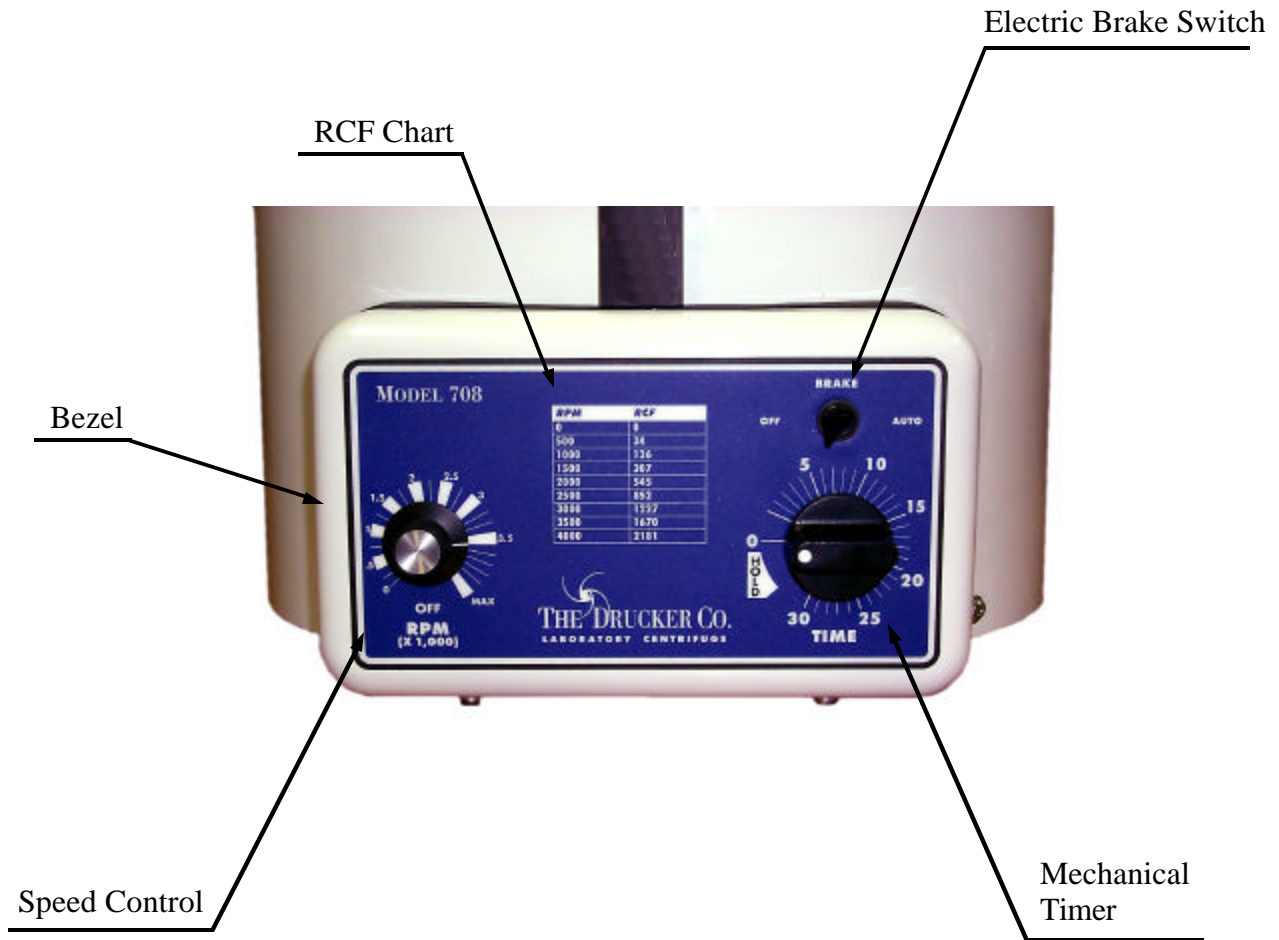

Figure 2A

Model 708
Control Panel
Rear View

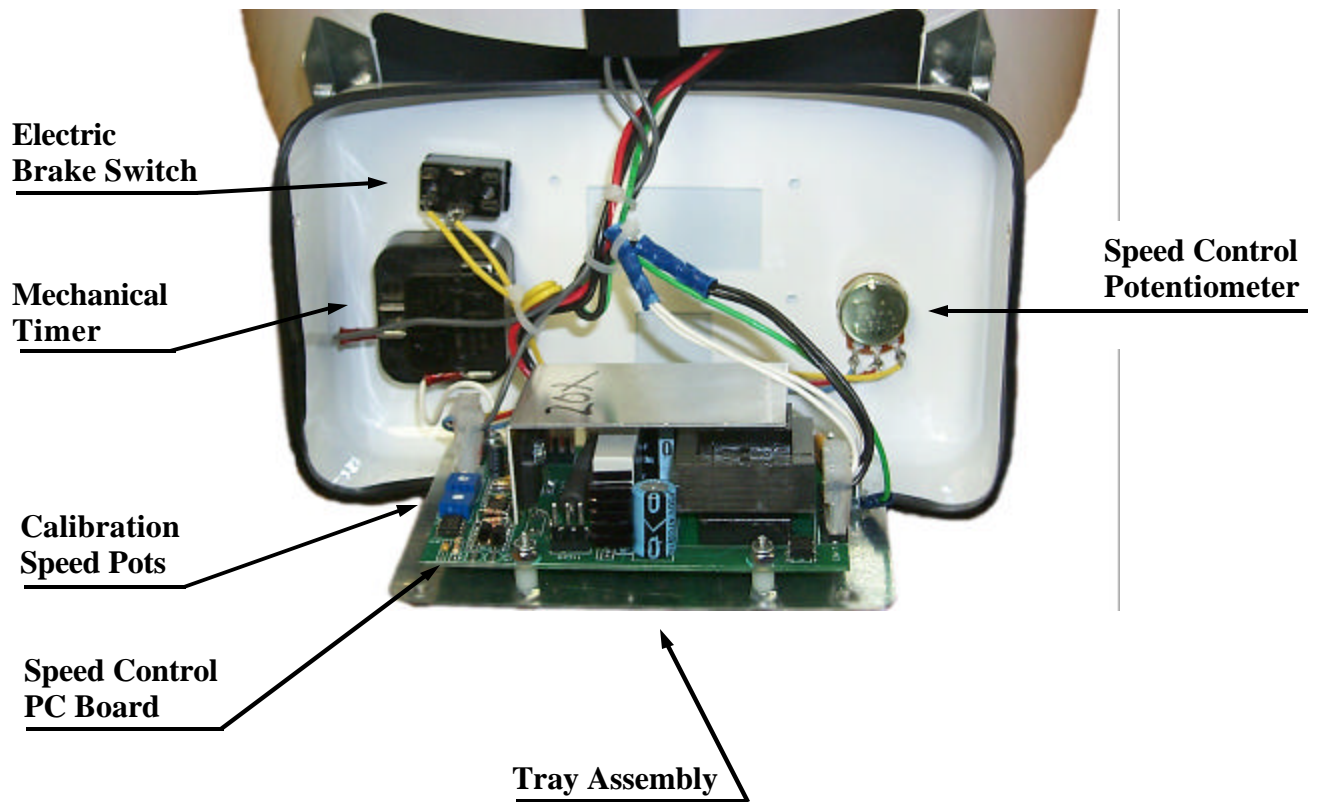

Figure 2B

5.0 Proper Balancing:

Note: All centrifuges have critical speeds at which vibration occurs. As the speed increases beyond the critical speed, vibration will diminish. This inherent condition also occurs during deceleration. An unbalanced load intensifies the effect of these critical speeds.

If excessive vibration is noticed in normal laboratory use, the cause is most likely due to an unbalanced load. To attain a balanced load, use the following procedures:

- 1 The test tubes that are opposite each other in the rotor must be equal in mass and have the same center of gravity. Therefore, test tubes must be alike in shape, thickness and distribution of glass or plastic. The larger the test tubes, the more critical is this selection.
- 2 Use a laboratory balance with a sensitivity of at least one-tenth of a gram. Weigh all test tubes to be spun. Place equal weight test tubes across from each other in the rotor.
- 3 If necessary, fill a test tube, identical to the one with sample in it, with water to the same level as the test tube with sample so that they have as close to equal weight as possible. Place the water filled test opposite the sample test tube in the rotor. Repeat this procedure for each test tube of sample as required.
- 4 Verify that all test tubes rotate freely in their test tube shields. Start the centrifuge and spin the load at a medium speed of 2,000 RPM and observe any vibration.
- 5 If excessive vibration is evident, **DO NOT OPERATE THE CENTRIFUGE**; recheck the balance weight of each test tube and repeat the above procedure.
- 6 If excessive vibration still persists, **DO NOT OPERATE THE CENTRIFUGE**; Remove all test tubes **and Test Tube Shields** from the centrifuge. Run the centrifuge at 2,000 RPM. If the vibration still exists call your Authorized Dealer or The Drucker Company.
- 7 If the centrifuge runs smoothly after step 5.0.6 the vibration problem is either in the weight of the samples or the test tube shields themselves.
- 8 Make certain that all the test tube shields are clean and empty and reinsert them in the centrifuge rotor. Restart the centrifuge per section 5.0.5.
- 9 If the centrifuge runs smoothly the problem was due to extra tube cushions, dirt or excess material in one or more of the test tube shields. Reinsert the sample test tubes and continue.
- 10 If the vibration is still present after step 5.0.9, weigh each test tube shield. They should be equal in weight to within 0.1 grams. If they are not, order a new set of test tube shields.

6.0 SERVICE

This section contains instructions for Operator servicing of the Drucker Model 708 centrifuge. It is not intended to be a comprehensive description of servicing instructions or procedures but rather a guide to help a qualified service technician resolve minor operational problems. Servicing of the centrifuge must be carried out by a qualified service technician. Attempted service by anyone other than a qualified service technician will void any Drucker warranty.

6.1 Drucker Service Philosophy

All Drucker centrifuges are designed for maximum serviceability. A Model 708B may be completely repaired (i.e.: replacement of all the main serviceable parts) in approximately one hour. For example: the main control panel, which contains all the input/output regulating devices to drive the Model 708, is harness connected to the motor and is replaceable in approximately 15 minutes.

6.2 Motor Brush Replacement

The electrical motor in the model 708 centrifuge is a DC motor designed to our particular specifications. Under normal use the motor brushes should have to be replaced every (500) hours or once each six months. When the brushes need replacement follow the following procedure:

1. Unplug the centrifuge from its electrical socket and turn it over so it is resting on its top.
2. Remove the bottom cover plate by taking the six (6) screws out of the bottom.
3. Using a short, flat bladed screwdriver, remove the black plastic motor brush cap located on each side of the motor.
4. Remove the old motor brush and replace with Drucker part number 7735047 motor brush. Make sure to orient the brush so that the curve on it matches the shape of the motor.
5. Replace the motor brush cap.
6. Rotate the centrifuge to its other side and repeat steps 6.2.1 through 6.2.5 for the second motor brush.
7. Inspect the old motor brushes. If the carbon has worn down to the bare metal, the motor armature may have been damaged. If this has happened, ***Do not operate the centrifuge;*** have a technician remove the motor and have the armature repaired.
8. Replace the bottom cover plate and return the centrifuge to an upright position.
9. Plug the centrifuge into a proper electrical socket.
10. Set the speed control to 2,000 RPM and turn the time to (5) minutes; if the centrifuge starts up and operates normally it is ready for continued operation; If unusual sounds are heard or there is excessive vibration, ***Turn off immediately, do not proceed.*** Call a repair technician or The Drucker Company for help in locating the problem cause.

6.3 Troubleshooting

Before attempting Operator service on the Model 708B, refer to Table 6.1 (on the following pages) for the most probable cause of a malfunction.

TABLE 6.1
TROUBLESHOOTING

Symptom	Possible Cause	Suggested Solution
1. Centrifuge does not operate when power (Timer) is turned on.	Centrifuge not plugged in.	Check that the line cord is properly plugged into the electrical outlet.
	The DC Board has not completed charging	Initially, the DC control board may need a few seconds to charge some components. A several second delay is normal at startup. Starting up at a slower speed may also require more time for this to complete.
	The lid switch is not closed	Make sure that the lid switch is turned completely clockwise. A 'click' should be heard indicated that the switch is closed.
	Blown fuse.	Replace fuse. If fuse blows again, call a service technician.
	Defective Speed Pot	Have a technician replace the speed control.
	Defective Timer	Have a technician replace the Timer.
	Disconnected wire	Remove the control panel and have a technician check all wires and connections.
	Motor unplugged from the Control Panel	Remove the control panel and have a technician check the motor connection to the main harness.
2. Centrifuge does not reach Set speed.	Defective Motor	Have a technician replace the Motor.
	Worn Motor Brushes	If the motor brushes are allowed to wear down to the bear metal the motor will short out. If the Armature is not too badly damage, replace the motor brushes.
	Improperly calibrated speed control.	See Section 8.0 on Calibration.
	Defective speed control.	Have a technician replace the speed control.
	Low line Voltage.	Verify that the line voltage is at least 110 volts.
	Defective Motor	Have technician replace the motor.
	Worn Motor Brushes	If the motor brushes are badly worn, but not to the bear metal, the motor may run intermittently. Replace the motor brushes.

TABLE 6.1 (Continued)

Symptom	Possible Cause	Suggested Solution
5. Unit will not brake.	Brake switch not on.	Turn on brake switch.
	Brake switch defective.	Have a technician replace switch.
6. Rotor begins rotation at "0" RPM	Defective Control Board	Have a technician replace the PC Board
	Improperly calibrated Speed Control.	See Section 8.0 on Calibration.
7. Motor rotates Intermittently	Defective motor.	Have a technician replace motor.
	Intermittent short in circuit	Have technician troubleshoot the electrical circuit.
8. Test tubes break during a run.	Speed setting too high for Test Tubes.	Reduce speed to correct setting; check for proper laboratory protocol,
	Test tubes inserted too far into test tube shields.	Use the right Test Tube Cushion; Insert the test tubes in the tube shields such that the test tube stoppers are fully exposed and the test tube rests flat against the tube shield wall.
	Dirty test tube shields.	Remove and clean all test tube shields.
	Foreign material embedded in test tube cushion.	Replace tube cushions.
	Weak Test Tubes	If possible, spin samples using a different manufacturer or an earlier lot. Contact the Test Tube manufacturer for possible lot control problems.
Excessive Vibration	Refer to section 5.0 on Balancing.	

TABLE 6.1 (Continued)

Symptom	Possible Cause	Suggested Solution
9. Excessive Vibration.	Too many tube cushions in one or more tube shields.	Verify that only one tube cushion is in each tube shield and all tube cushions are the same size.
	Out-of-balance samples	Refer to Section 5.0 on Balancing.
	Out-of-balance Rotor	Remove all test tubes and tube shields from the rotor. Spin centrifuge at 2,000 RPM. If the vibration persists, Check the rotor for foreign deposits. If none are found replace the rotor or return it to The Drucker Company for balancing.
10. Rotor does not spin freely.	Defective motor bearings	Remove the Motor and return it to The Drucker Company for repair.
	Rotor rubbing on rubber rubbing on rubber boot	Have a technician raise and realign motor
11. Centrifuge body or motor overheating	Blocked air inlets or Blocked air exhaust	Verify that the holes in the center of the lid are not blocked for proper air intake and that the slots in the base, inside the rotor chamber or the slots in the underside of the cabinet are not blocked and are providing proper air exhaust.
	Defective motor	Have a technician replace the motor

7.0 MAINTENANCE

The following Preventative Maintenance procedures are to ensure consistent operation of the centrifuge and should be performed only by qualified personnel with a basic understanding of Electro-mechanical devices and laboratory instrumentation.

7.1 Centrifuge Cleaning

No daily cleaning of the centrifuge is required, however, in the event of tube breakage or spillage in the rotor chamber the centrifuge should be thoroughly cleaned immediately.

Caution: Always wear proper protective equipment and apparel.

1. If sample material has spilled into the centrifuge or on the accessories, exercise care and proper laboratory protocol for the handling of spilled samples.
2. Remove the rotor and any accessories (wash these per section 8.2).
3. Wash the inside of the centrifuge with a strong bleach solution or recommended laboratory disinfecting solution. Scrub with a stiff brush if necessary.

Caution: Wash with a wet cloth or sponge only, do not flush guard bowl with liquid unless it is equipped with the optional Guard Bowl clean out.

4. Thoroughly dry the inside of the guardbowl.

7.2 Accessory Cleaning

1. Remove the rotor and test tube shields using proper protective measures for the handling of spilled samples as outlined your laboratory protocol.
2. Properly dispose of any broken or damaged test tubes and spilled samples.
3. Remove any test tube cushions from the test tube shields.
4. Wash the accessories with a strong bleach solution or recommended laboratory disinfecting solution. Scrub with a stiff brush if necessary.
5. Oven dry the accessories .
6. Install new tube cushions in the test tube shields.
7. Reinstall the test tube shields in the centrifuge rotor.

8.0 VERIFICATION/CALIBRATION

8.1 Speed Verification/Calibration

In order to perform a speed calibration you will need an optical tachometer, suitable targets and a small flat head screwdriver.

1. Weigh out (20) test tubes filled with water such all test tubes weigh the same within 0.1 grams.
2. Insert the water filled test tubes into the test tube shields in the rotor.
3. Clean the top surface of the centrifuge rotor and affix a suitable reflective target.
4. Rotate the Speed Control knob to 3000 RPM.
5. Set the Timer to 15 minutes.
6. Once the speed seems uniform place a calibrated optical tachometer over one of the holes in the centrifuge lid.
7. Measure the rotational speed of the rotor assembly with the optical tachometer.
8. If the measured speed matches the speed set on the control panel to within 100 RPM the Speed Control is properly calibrated.
9. If the measured speed varies by more than 100 RPM from the speed set on the control panel;
 - a) Stop the centrifuge.
 - b) Remove the control panel.
 - c) Adjust the max speed trim pot, (clockwise for increased speed), checking the speed with the tachometer until the rotor speed is correct. Refer to Figure 4.
 - d) If necessary, adjust the zero-point trim pot to affect the low end.
10. Repeat steps 8.1.4 through 8.1.8.
11. Repeat as necessary until the speed setting on the control panel matches the measured speed to within 100 RPM.

8.2 Time Verification/Calibration

In order to perform a Time calibration you will need a calibrated stop watch.

1. Set the speed control to 2,000 RPM.
2. Set the Time for 15 minutes and immediately start the stop watch.
3. As soon as you hear the the mechanical timer time out to "0" stop the stop watch.
4. There are no adjustments on the Timer module; If the measured time variance is unacceptable, replace the timer.

Model 708 DC Control Board

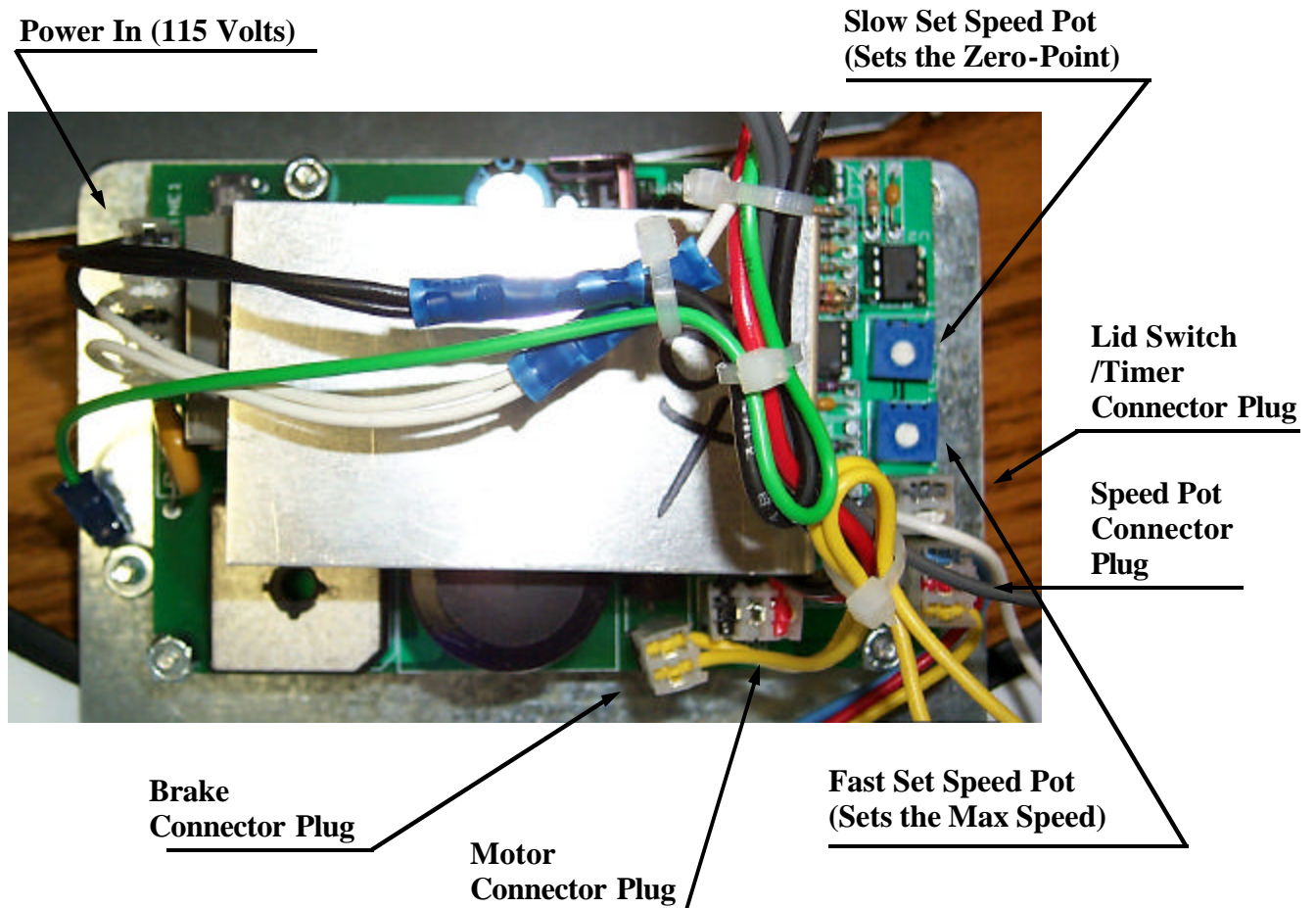

Figure 3

9.0 Relative Centrifugal Force (RCF)

The motor driven rotation of the centrifuge results in a force being applied to the samples it contains. This relative centrifugal force, or **RCF**, may be critical in some laboratory applications. The **RCF** stated in these instructions is an approximate value that is subject to variations due to acceleration and braking times. During acceleration and braking periods, the speed of the centrifuge is less than the speed value set by the operator. The true cumulative **RCF** value is affected most by short run times and heavier rotor loads, since they take longer to accelerate and decelerate.

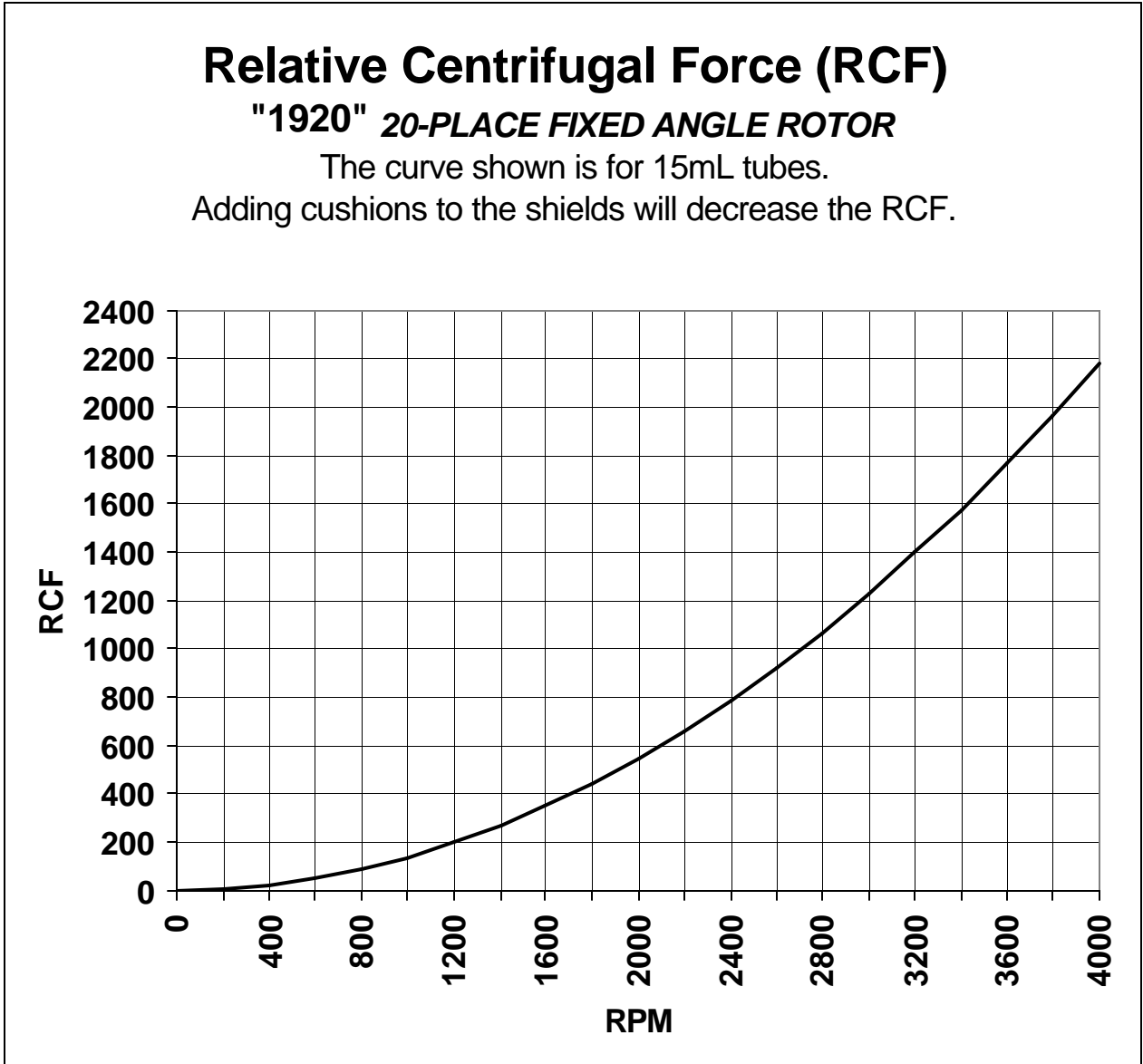

Figure 4

10.0 WARRANTY INFORMATION:

The Drucker Company warrants that it will repair or replace, at its option, free of charge, any centrifuge that fails after delivery to the original customer because of defective material or workmanship (provided it has not failed under the exceptions and conditions specified in the warranty given with the instrument), but within the following time periods:

- a. One (1) year warranty on the centrifuge and its accessories from the time of purchase.
- b. Sixty (60) day warranty on all replacement parts supplied after the warranty period.

Note: All failed/serviced parts must be returned to the factory before full warranty allowance or credit will be given.

Such exceptions and conditions include, but are not limited to, failure of parts due to improper use, accident, neglect, acts of God or operation in a manner not prescribed in this **Installation and Operation Manual**. The foregoing expresses The Drucker Company's sole warranty with respect to the centrifuge. This warranty is made in lieu of any and all other warranties and all implied warranties of merchantability and fitness for a particular purpose are hereby disclaimed and excluded. The Drucker Company and its authorized dealers will not be liable for consequential damages, losses, or expenses arising from the improper use of the centrifuge. The Drucker Company will not honor any other warranty given by the authorized dealer that is different from the warranty given by The Drucker Company. This warranty is not assignable and is operative only in favor of the original customer to whom this warranty is delivered.

10.1 Dealer Obligation Under Warranty:

Customers requesting service for an instrument during the period covered by the warranty should receive a response within a 48-hour period from the authorized dealer who sold the instrument. If this obligation is not met and the customer so advises The Drucker Company, such authorized dealer will be notified of, and will be held responsible for, the action taken and expenses incurred by The Drucker Company in satisfying the customer.

10.2 Disclaimers and Exclusions:

This Installation and Operations Manual includes a troubleshooting section. However, the customer is under no obligation to locate or remedy any service problem. The customer hereby releases and forever discharges The Drucker Company, its successors, assigns, subsidiaries, affiliates, officers, agents, and employees from any and all claims, demands and liabilities in law or in equity, of any nature, based upon, arising out of, or resulting from locating, remedying, or attempting to locate or remedy any service problem. If service is required, the customer should contact the dealer from whom the instrument was purchased to obtain service by factory-trained personnel, or return the instrument to The Drucker Company for factory repair.

10.2 Disclaimers and Exclusions (Continued)

The information included in this Installation and Operation Manual is believed adequate for the operation and intended use of this centrifuge. If the centrifuge is to be used for any purpose exceeding or deviating from the capabilities specified herein, then written conformation of acceptability for such purpose should be obtained from The Drucker Company. Failure to do so may affect the warranty. The Drucker Company will not guarantee any results nor assume any obligation or liability arising from such action.

To obtain service and/or replacement parts under warranty, the customer should contact The Drucker Company dealer from whom the instrument was purchased, or:

THE DRUCKER COMPANY, Inc.

**200 SHADY LANE
PHILIPSBURG, PENNSYLVANIA 16866
TEL: (814) 342-6205 FAX: (814) 342-6211**

Your correspondence must include the model and serial numbers of the instrument, the date of its delivery, and the name of the dealer from whom the instrument was purchased. The Drucker Company can not accept goods returned without proper authorization. A "Returned Goods Authorization" must be obtained through a dealer or the factory, and must accompany the prepaid return shipment.

To obtain service and/or replacement parts not under warranty, or to order additional accessories, the customer should contact the factory or any authorized dealer.

NOTE: In the event the customer wishes to return the instrument or any part thereof, the customer must comply with the following requirements:

- a Decontaminate the instrument or any part that has been exposed or used to process potential pathogenic or radioactive material. Decontamination must be performed to ensure no radioactivity or harmful bacteria is present and the customer must advise The Drucker Company accordingly.
- b Decontaminate the instrument or any part that may have accumulated blood or any other chemical deposits by using standard laboratory procedures. If this instrument or any part thereof is received in a condition The Drucker Company considers to be a potential biological hazard to its personnel, the instrument will be returned to customer unrepaired along with a report of the Company's findings. The centrifuge will be returned to the customer at the customer's expense.