



Drucker Diagnostics

Innovative Solutions for a Healthier World

200 Shadylane Drive
Philipsburg, PA 16866

Phone: (814) 342-6205
Fax: (814) 342-4510
www.druckerdiagnostics.com

Service Manual

Model 755VES Centrifuge

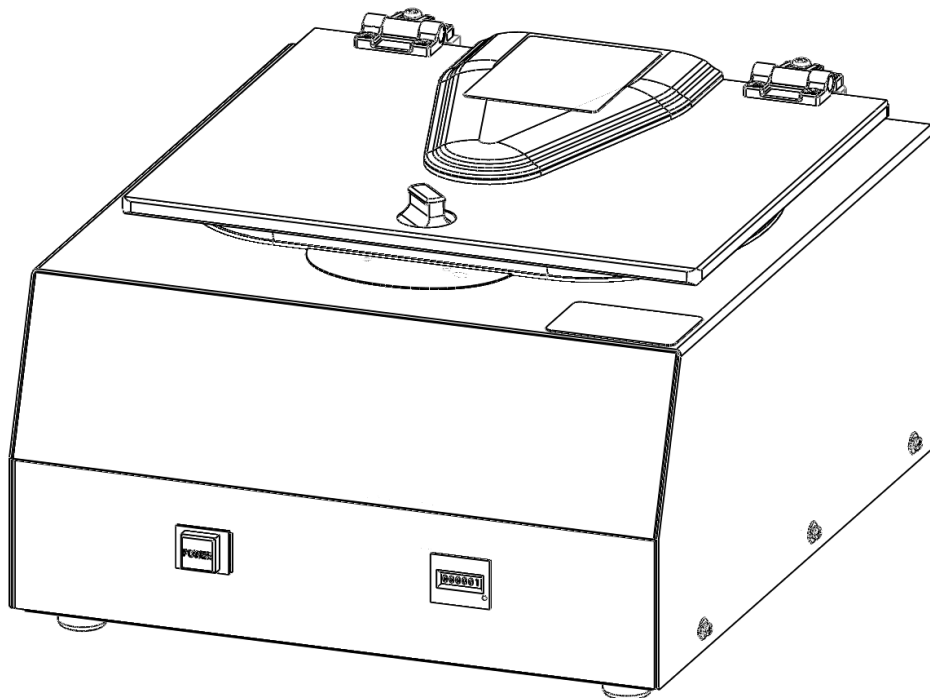

CONTENTS

1	PREFACE.....	3
2	GENERAL DESCRIPTION OF MAJOR COMPONENTS	3
3	WARRANTY INFORMATION	3
4	SPECIFICATIONS.....	3
5	TROUBLESHOOTING	4
6	SERVICE INSTRUCTIONS.....	5
7	WIRING DIAGRAM (115V MODELS).....	12
8	WIRING DIAGRAM (230V MODELS).....	13
9	FINAL CENTRIFUGE ASSEMBLY	14
10	CABINET ASSEMBLY	15
11	LOWER ASSEMBLY	16
12	GUARD BOWL ASSEMBLY	17
13	REVISION HISTORY.....	18

1 PREFACE

- 1.1 The purpose of this manual is to provide the service technician with information for troubleshooting, testing, and repair of laboratory centrifuge model 755VES. Only qualified technically trained personnel should attempt any of the servicing described in this document. Failure to follow the procedures in this document may result in personal injury or instrument damage. The Drucker Company will not be held liable for any injury or damage as a result of improper servicing.
- 1.2 Information contained within this manual is subject to change without notice.

2 GENERAL DESCRIPTION OF MAJOR COMPONENTS

- 2.1 Motor: Brushless DC Motor
- 2.2 Printed Circuit Board: The PCB is the microcontroller based control center of the centrifuge. All control signals are generated in the PCB.
- 2.3 Lid Locking Tray Assembly: The lid tray assembly contains a solenoid and limit switch that are used to determine the state of the lid (Open or Closed) and to keep the lid locked during centrifugation cycles.
- 2.4 Rotor: The centrifuge rotor is the main component that spins in the centrifuge. The rotor is loaded with tube holders, and the samples are placed into the tube holders for processing.

3 WARRANTY INFORMATION

- 3.1 The Drucker Company warrants its centrifuges to be free from defects in workmanship and parts for two years.

4 SPECIFICATIONS

Maximum Speed	4300 RPM
Maximum RCF	3150
Maximum Capacity	24 Tubes (17 x 100mm) 12 Tubes (17 x 125mm)
Dimensions (in)	9.0 (H) x 14.5 (W) x 16.5 (L)
Environmental Operating Range	2-40 deg C
Typical Noise Level (At Maximum Speed)	< 70 dB A
Electrical Ratings	
115VAC Version	115VAC (+/- 10V)
230VAC Version	230VAC (+/- 20V)

5 TROUBLESHOOTING

PROBLEM	POSSIBLE CAUSE	SOLUTION
The lid does not open.	No Power	Check removable line cord
	No Power	Check circuit breaker on underside of centrifuge.
	No Power	Check wall outlet
	Lid knob is ajar	Rotate the lid knob fully clockwise before pressing the 'OPEN' button
	Lid lock is active (Unlock timed out)	Press the 'OPEN' button to de-activate the lid
	Lid tray is unplugged from PCB or defective	Requires service
	PCB is damaged	Requires service
		To gain access to the rotor - Remove the 'OPEN/CLOSE' sticker and slide the lid latch lever toward the front of the centrifuge. This will unlock the lid.

PROBLEM	POSSIBLE CAUSE	SOLUTION
Excessive vibration	Rotor improperly loaded	Load equally filled tubes symmetrically in the rotor. All carriers and/or tube holders must be present in the rotor, whether loaded, or empty.
	Debris lodged within the rotor or tube carriers	Carefully inspect all rotor pockets, tube holders and crevasses for debris.
	Centrifuge housing is loose	Requires service
	Missing/damaged feet	Requires service
	Motor failure	Requires service
	Rotor damaged	Replacement required

PROBLEM	POSSIBLE CAUSE	SOLUTION
Rotor does not spin	No Power	Check removable line cord
	No Power	Check circuit breaker on underside of centrifuge.
	No Power	Check wall outlet
	Lid not properly latched	Press down firmly on lid and rotate lid knob clockwise until the 'LATCHED' light illuminates.
	Internal connection failure	Requires service
	PCB failure	Requires service
Motor Failure	Requires service	

PROBLEM	POSSIBLE CAUSE	SOLUTION
Clicking noise during braking	Rotor is loose	Tighten rotor screw per section 7-2

PROBLEM	POSSIBLE CAUSE	SOLUTION
Whistling noise while running	Debris in air intake / exhaust ports	Remove power before clearing debris.
	Gasket failure	Requires service

PROBLEM	POSSIBLE CAUSE	SOLUTION
Error message is displayed		
'OVRSPD'	Rotor speed is too great - Internal error	Service required
'SPEED'	Rotor Speed is under set speed for too long.	Check power supply
	Rotor Speed is under set speed for too long.	Check rotor – Missing carriers can reduce rotor speed in some models. All carriers must be installed whether full or empty.
	Rotor Speed is under set speed for too long.	Check the lid and guard bowl gaskets. Voids in the rotor chamber gaskets change the airflow, resulting in increased stress on the motor drive.
	Rotor speed is over set speed for too long	Service required
'BALANC'	Rotor improperly loaded	Load equally filled tubes symmetrically in the rotor. All carriers and/or tube holders must be present in the rotor, whether loaded, or empty.
	Debris lodged within the rotor or tube carriers	Carefully inspect all rotor pockets, tube holders and crevasses for debris.
	Rotor damaged	Replacement required
'ROTOR'	Software selection of rotor is unknown	Service Required – Call Drucker technical service.

6 SERVICE INSTRUCTIONS

6.1 Cleaning

- a) The cabinet, rotor top and accessories shall be thoroughly cleaned using soap and water, isopropyl alcohol, or a mild bleach solution.
- b) Under no circumstances should any of the following be used: Fully/Partially Halogenated Hydrocarbons, Ketones and Esters.
- c) Use of any chemicals not prescribed by the manufacturer may cause damage to the rotor and tube carriers / holders and shall not be used.

6.2 Removing the Rotor

- a) Use a 1/8" hex key to loosen the center rotor screw (turn counter-clockwise).
- b) Lift the rotor straight up and out of the rotor chamber.
- c) To install the rotor, reverse steps A and B above. Take care to align the hub spines and/or shaft cross pin with the rotor hub. Tighten the rotor screw to 3.5 Nm.

6.3 Maintaining the Rotor

- a) Keep the rotor clean, any corrosive materials must not be allowed contact with the rotor and should be cleaned immediately.
- b) The rotor should be checked periodically for signs of wear.
- c) Remove the rotor from service if any of the following are found: cracks, deep scratches, corrosion or discoloring.

6.4 Rotor Screw

- a) If the rotor screw needs to be tightened, use a 1/8" hex key and tighten to 3.5 Nm.

6.5 Speed Calibration

- a) Check the centrifuge speed periodically, we recommend every two years.
- b) Important: When verifying rotor speed, make certain that all carriers are installed in the rotor.
- c) No calibration adjustment of speed can be made, only a verification of rotor speed.

6.6 Line Leakage

- a) Check the centrifuge's line leakage periodically, we recommend every two years.
- b) All Drucker centrifuges currently manufactured are classified as "laboratory equipment", per the requirements of UL 61010-1 Electrical Equipment for Measurement, Control and Laboratory Use; Part 1: General Requirements. This standard specifies that the maximum current levels between any accessible parts are as follows:
- c) In normal condition the maximum current flow between accessible parts is 0.5mA RMS for sinusoidal waveforms, 0.7mA peak for non-sinusoidal waveforms or mixed frequencies, or 2mA DC.

- d) In single fault condition the maximum current flow between accessible parts is 3.5mA RMS for sinusoidal waveforms, 5mA peak for non-sinusoidal waveforms or mixed frequencies, or 15mA DC.

6.7 Ground continuity

- a) Check the centrifuge's ground continuity periodically, we recommend every two years.
- b) Disconnect the manufacturer's supplied power cord from the power supply.
- c) Measure the resistance between the ground tab of the line cord and an exposed, clean, unpainted metal surface contiguous to the chassis main frame.
- d) The maximum acceptable ground resistance is 0.1 Ohms.

6.8 Removing the Cabinet (Upper Housing)

- a) There are eight screws that fasten the centrifuge cabinet to the base.
- b) Begin by unplugging the centrifuge, and waiting 10 minutes for internal voltages to dissipate.
- c) Use a #2 Phillips screwdriver to remove the cabinet screws (three on left and right sides, two in the rear)
- d) The cabinet control panel is attached to the base internally with cable harnesses. Be careful not to stress the cables when removing the cabinet.
- e) Stand directly in front of the centrifuge and lift the cabinet straight up and off the base, setting it down on its right side.
- f) Gently remove the power supply and motor harnesses from the PCB.
- a) Use a Volt meter to measure the DC voltage across the power supply capacitor.

IMPORTANT: Do not continue until the voltage is below 0.5 V DC. See fig 4



Fig 4

- b) Once the voltage is below 0.5 V DC short the capacitor with a screwdriver. See fig 5

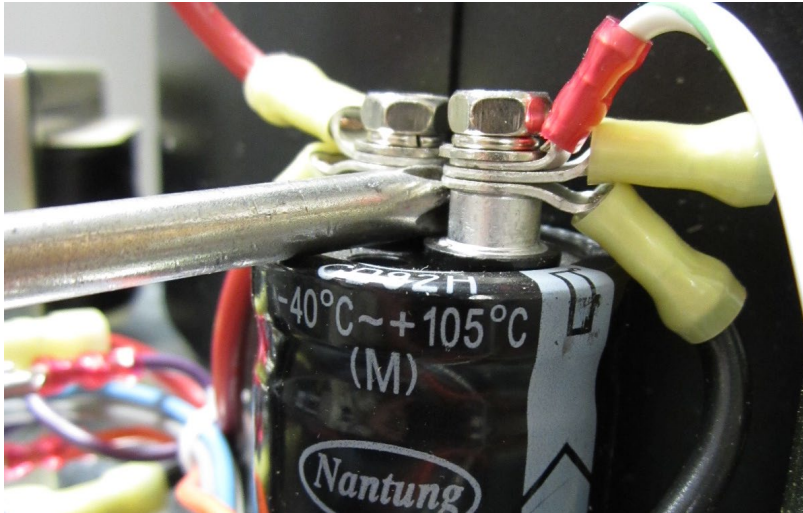

Fig 5

- c) Service may continue once the capacitor is drained.

6.9 Replacing the Lid Tray Assembly

- a) The lid tray assembly is accessible once the cabinet has been removed.
- b) Gently remove the lid tray wire harness from the PCB.
- c) The lid tray assembly is held in place with two #6 Nylok nuts. Use a 5/16" nut driver to remove the nuts. The tray will slide off the threaded studs.
- d) Early models used a plastic spacer between the tray assembly and the metal cabinet. A spacer is no longer needed. **IMPORTANT: Remove any plastic spacer that may be present.**
- e) To install the lid tray, slide it onto the studs, and secure it with two #6 Nylok nuts, hand tight.
- f) Complete the installation by gently plugging the wire harness into the PCB header 'J4'. The header and connector are keyed for proper orientation.

6.10 Replacing the PCB

- a) The PCB is accessible once the cabinet has been removed. Make certain that all wire harnesses have been disconnected. Use standard precautions for handling static sensitive components.
- b) The PCB is held in place with nine #6 Nylok nuts and plastic insulator washers. Use a 5/16" nut driver to remove the nuts. The PCB and washers are now free to slide off the threaded studs.
- c) Beneath the PCB are seven plastic standoffs. If they are crushed, replace them before reassembly.
- d) To install the PCB, make certain that seven plastic standoffs and two rubber spacers are present on the control panel studs.

- e) Slide the board onto the studs
- f) Install seven plastic washers onto the studs securing the circuit card.
- g) Install two conventional #6 washers onto the heat sink studs.
- h) Important: Secure the heat sink side of the PCB first, and tighten the Nylok nuts until the stud protrudes past the Nylok Nut by only one thread.
- i) Important: over tightening the PCB nuts will cause malfunction – Each nut sets the height of a separate control panel switch. Too low, and they cannot be actuated, too high and they jam against the front panel label, and are always in the 'ON' state.
- j) The remaining 7 nuts should be tightened only until the buttons on the control panel click when pressed – do not over tighten. Each nut sets the height of a separate control panel button. Tighten each nut a ¼ turn in succession, trying each corresponding button as you go.
- k) Once each control panel button clicks when pressed, installation is complete.

IMPORTANT: Do not connect the power supply to the PCB yet. Follow the instructions in section 6.13

6.11 Removing the motor

- a) Remove the cabinet assembly by following 6.8
- b) Cut and remove all wire harness zip ties.
- c) Flip the base assembly up-side down and remove the three exhaust air channel screws with a #2 Phillips driver.
- d) Set the exhaust cover aside
- e) The guard bowl is held in place with six #8 screws. Remove them with a #2 Phillips driver.
- f) Lift the base assembly off of the guard bowl and set it aside.
- g) Flip the guard bowl.
- h) The motor is held in place with 4 #8 Nylok nuts. Remove them with an 11/32" nut driver.
- i) Slide the motor and motor gasket out of the guard bowl's motor well.

6.12 Replacing the motor

- a) Make certain that a new gasket is used when installing a motor.
- b) Locate the seam on the inside of the guard bowl wall.
- c) Position the motor so its wires exit approx 180 deg away from the guard bowl seam.
- d) Install the motor and gasket into the guard bowl with the wire harness positioned as described above.

- e) Drive 4 #8 Nylok nuts onto the motor studs with an 11/32" nut driver.
- f) Turn the guard bowl assembly upside down with the guard bowl seam facing you.
- g) Place the base assembly (with transformers facing you) onto the guard bowl.
- h) **IMPORTANT: Make certain that no wires are pinched between the guard bowl and base!**
- i) **IMPORTANT: Tuck a portion of the motor wire harness into the rectangular cutout in the base. See fig 1.**



Figure 1

- j) **IMPORTANT: Make certain that the base assembly wires are routed between the base and the threaded screw inserts. See fig 2.**



Figure 2

- k) Fasten the guard bowl to the base with six each #8 screw, washer and lock washers.
- l) Install the exhaust air cover with 3 each #8 screw, washer and lock washers. Make certain that the motor wire harness is contained within the cover's wire channel. See fig 3.



Fig 3

- m) Replace the zip tie removed in 6.11
- n) The lower assembly is complete.

6.13 Power Connections and Final Assembly

IMPORTANT: These steps must be followed to avoid personal harm and to avoid damaging the PCB.

- d) Make certain that the lower assembly has been unplugged from the mains supply for at least 10 minutes.
- e) Use a Volt meter to measure the DC voltage across the power supply capacitor.

IMPORTANT: Do not continue until the voltage is below 0.5 V DC. See fig 4



Fig 4

- f) Once the voltage is below 0.5 V DC short the capacitor with a screwdriver. See fig 5

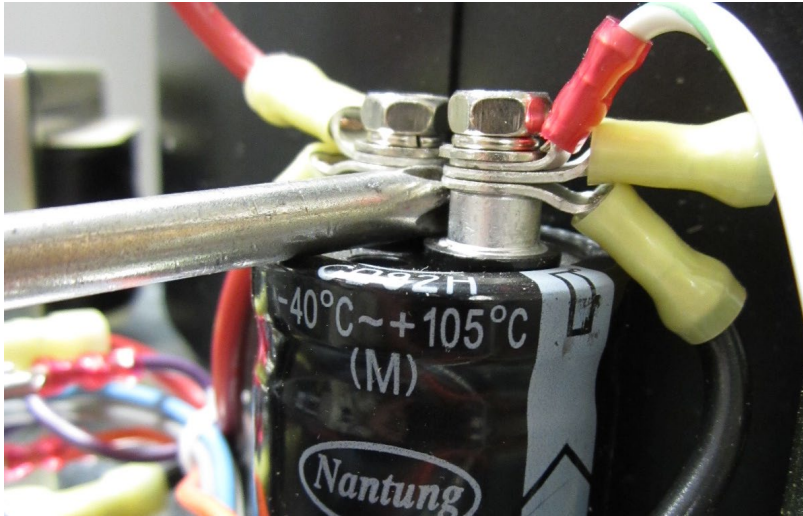

Fig 5

- g) Connect the power leads to the PCB. The positive lead (red) goes to 'J10' Negative (black) lead goes to 'J11'
- h) Connect the two motor connectors to 'J2' and 'J12' on the PCB.
- IMPORTANT: Remove the screwdriver before continuing**
- i) Carefully place the cabinet onto the base taking care not to pinch any wires between the two.
- j) Complete the assembly by replacing the eight #8 screws, washers and lock washers with a #2 Phillips driver.

7 WIRING DIAGRAM (115V MODELS)

WIRE IDENTIFICATION: TYPE AND LENGTH:

1. 03-1-0005-0031 - 14 INCH
2. 03-1-0005-0032 - 14 INCH
3. 03-1-0005-0025 - 16 INCH
4. 03-1-0005-0065 - 8 INCH
5. 03-1-0005-0064 - 11 INCH
6. 03-1-0005-0032 - 4 INCH
7. 03-1-0005-0031 - 6 INCH
8. 03-1-0005-0030 - 14 INCH
9. 03-1-0005-0029 - 14 INCH
10. 03-1-0005-0030 - 14 INCH
11. 03-1-0005-0029 - 20 INCH
12. 03-1-0005-0028 - 19 INCH
13. 03-1-0005-0029 - 28 INCH
14. 03-1-0005-0019 - 26 INCH
15. 03-1-0005-0024 - 6 INCH
16. 03-1-0005-0028 - 6 INCH

CONNECTOR IDENTIFICATION:

- A. DISCONNECT, .25", FEMALE, YELLOW (3081016)
- B. DISCONNECT, .125", FEMALE, RED (3081010)
- C. DISCONNECT, .25", FEMALE, YELLOW (3081016)
- D. DISCONNECT, .125", FEMALE, RED (3081010)
- E. TERMINAL, RING, 12-10 AWG (3081011)
- F. TERMINAL, RING, 12-10 AWG (3081011)
- G. TERMINAL, RING, 12-10 AWG (3081011)
- H. TERMINAL, RING, 12-10 AWG (3081011)
- I. CONN RING TERM #6 14-16 AWG (03-1-0005-0017)
- J. DISCONNECT, .25", FEMALE, RED (3081002)
- K. DISCONNECT, .25", FEMALE, RED (3081002)
- L. DISCONNECT, .25", FEMALE, RED (3081002)
- M. DISCONNECT, .25", FEMALE, RED (3081002)
- N. DISCONNECT, .25", FEMALE, RED (3081002)
- O. DISCONNECT, .25", FEMALE, YELLOW (3081016)
- P. DISCONNECT, .25", FEMALE, RED (3081002)
- Q. DISCONNECT, .25", FEMALE, RED (3081002)
- R. DISCONNECT, .25", FEMALE, YELLOW (3081016)
- S. DISCONNECT, .25", FEMALE, YELLOW (3081016)
- T. CONN RING TERM #6 14-16 AWG (03-1-0005-0017)
- U. CONN RING TERM #6 14-16 AWG (03-1-0005-0017)

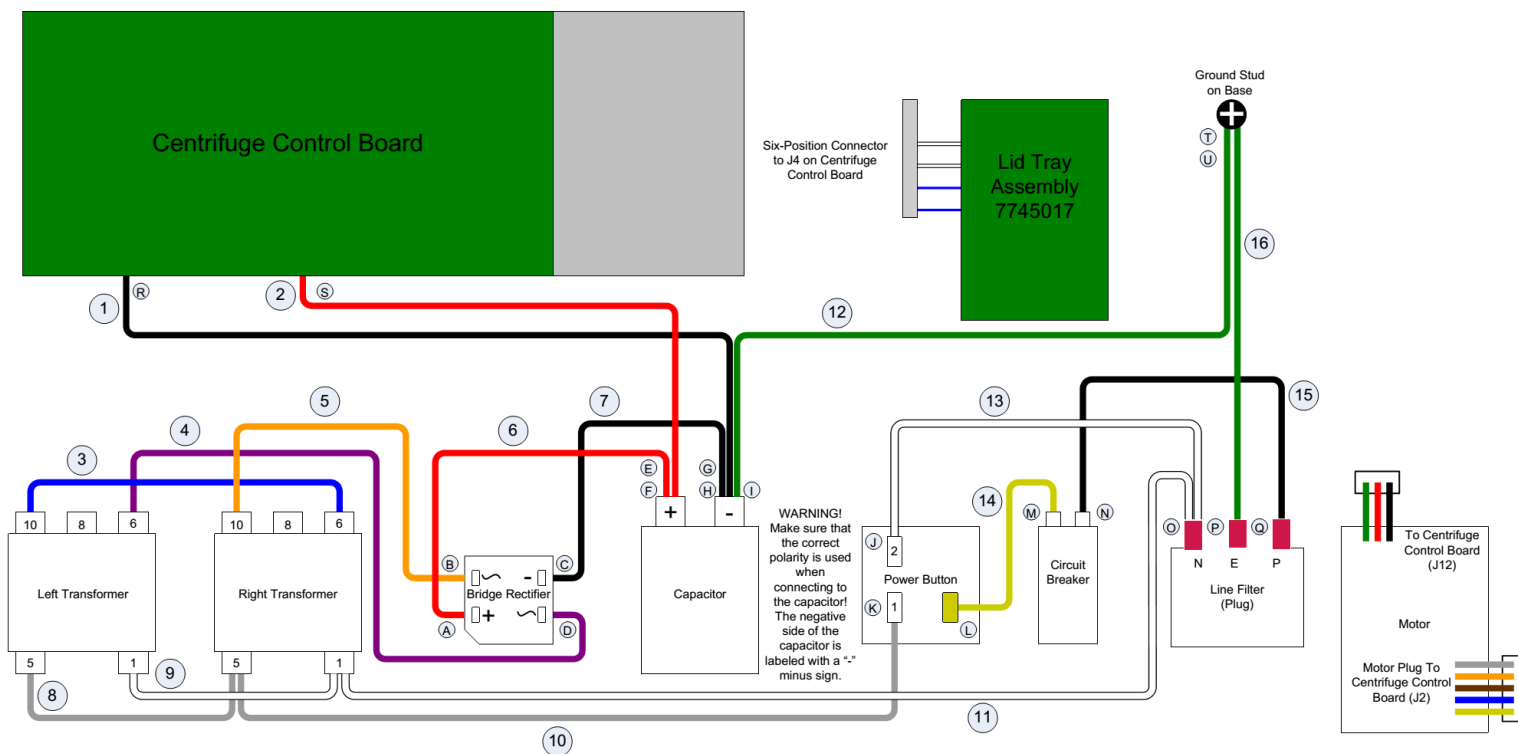

8 WIRING DIAGRAM (230V MODELS)

Wire Identification: Type, Length, and Connections:

1. 03-1-0005-0031 – 14 INCH – Disconnect, .25", Female, Yellow (3081016) & Terminal, Ring, 12-10 AWG (3081011)
2. 03-1-0005-0032 – 14 INCH – Disconnect, .25", Female, Yellow (3081016) & Terminal, Ring, 12-10 AWG (3081011)
3. 03-1-0005-0036 – 16 INCH – Soldered & Soldered
4. 03-1-0005-0027 – 8 INCH – Soldered & Disconnect, .125", Female, Red (3081010)
5. 03-1-0005-0026 – 11 INCH – Soldered & Disconnect, .125", Female, Red (3081010)
6. 03-1-0005-0032 – 4 INCH – Disconnect, .125", Female, Red (3081010) & Terminal, Ring, 12-10 AWG (3081011)
7. 03-1-0005-0031 – 6 INCH – Disconnect, .125", Female, Red (3081010) & Terminal, Ring, 12-10 AWG (3081011)
8. 03-1-0005-0037 – 14 INCH – Soldered & SHARED Soldered WITH #13
9. 03-1-0005-0033 – 2 INCH – Soldered & Soldered
10. 03-1-0005-0036 – 14 INCH – Soldered & SHARED Soldered WITH #14
11. 03-1-0005-0033 – 2 INCH – Soldered & SHARED Soldered WITH #12
12. 03-1-0005-0033 – 13 INCH – SHARED Soldered WITH #11 & Disconnect, .25", Female, Red (3081002)
13. 03-1-0005-0037 – 14 INCH – SHARED Soldered WITH #8 & Disconnect, .25", Female, Red (3081002)
14. 03-1-0005-0036 – 20 INCH – SHARED Soldered WITH #10 & Disconnect, .25", Female, Red (3081002)
15. 03-1-0005-0049 – 19 INCH – Conn Ring Term #6 14-16 AWG (03-1-0005-0017) & Conn Ring Term #6 14-16 AWG (03-1-0005-0017)
16. 03-1-0005-0037 – 26 INCH – Disconnect, .25", Female, Red (3081002) & Disconnect, .25", Female, Red (3081002)
17. 03-1-0005-0037 – 6 INCH – Disconnect, .25", Female, Red (3081002) & Disconnect, .25", Female, Red (3081002)
18. 03-1-0005-0049 – 6 INCH – Disconnect, .25", Female, Red (3081002) & Conn Ring Term #6 14-16 AWG (03-1-0005-0017)
19. 03-1-0005-0049 – 10 INCH – Conn Ring Term #6 14-16 AWG (03-1-0005-0017) & Conn Ring Term #6 14-16 AWG (03-1-0005-0017)

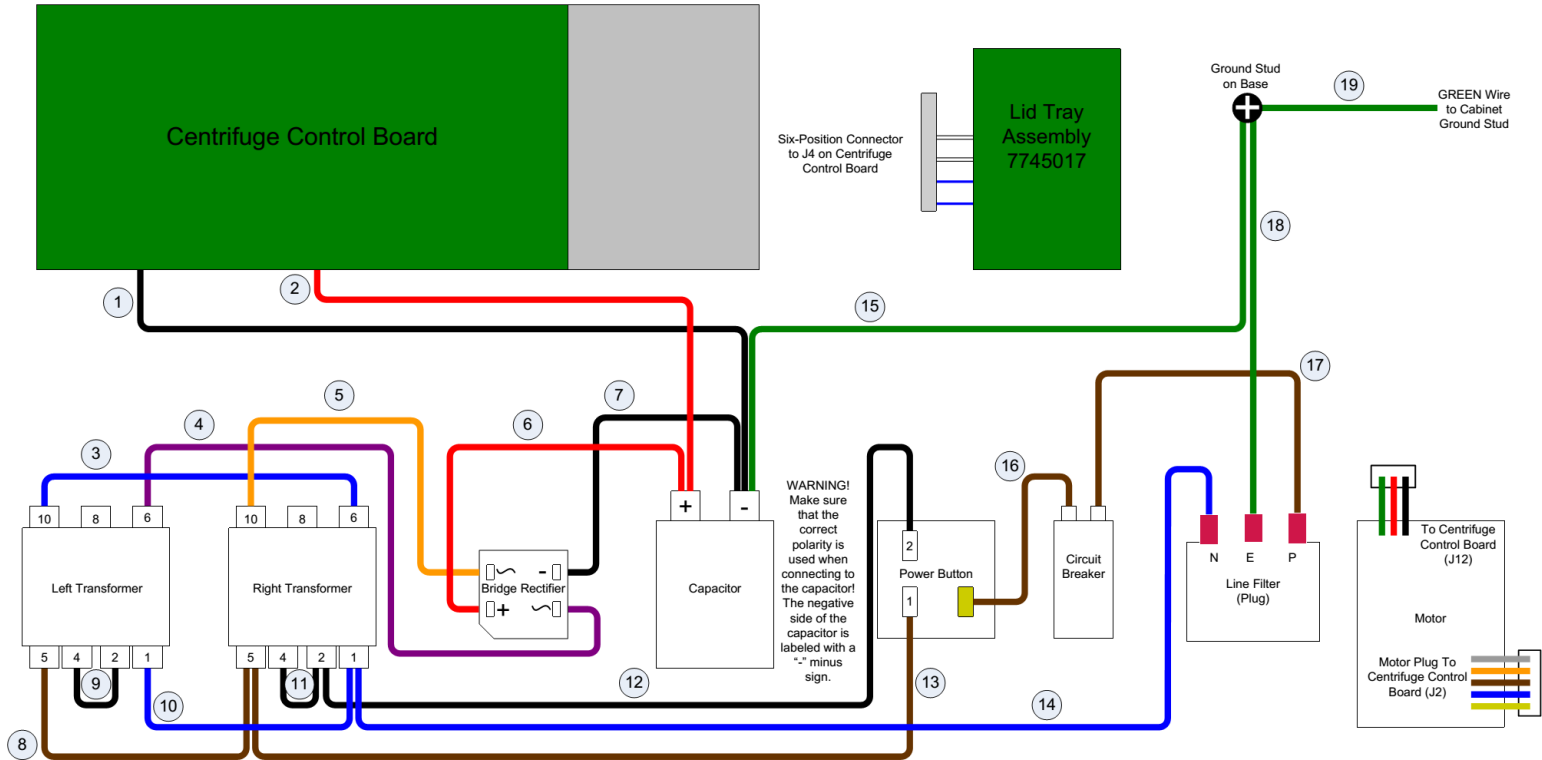

9 FINAL CENTRIFUGE ASSEMBLY

ITEM NO.	PART NUMBER	DESCRIPTION	QTY
1	OEM SPECIFIC	755 VES LOWER ASSEMBLY	1
2	OEM SPECIFIC	755VES CABINET & LID ASSEMBLY	1
3	3033003	WASHER #8, FLAT, SILVER	8
4	3033001	#8 SPLIT LOCK WASHER	8
5	3012007	SCREW, PHILLIPS, 8-32, 0.50 LONG	8
6	7724026	SERIAL NUMBER	1
7	OEM SPECIFIC	CARRIER REPLACEMENT LABEL	1
8	OEM SPECIFIC	FACTORY CALIBRATION LABEL	1
9	OEM SPECIFIC	FRONT PANEL LABEL	1

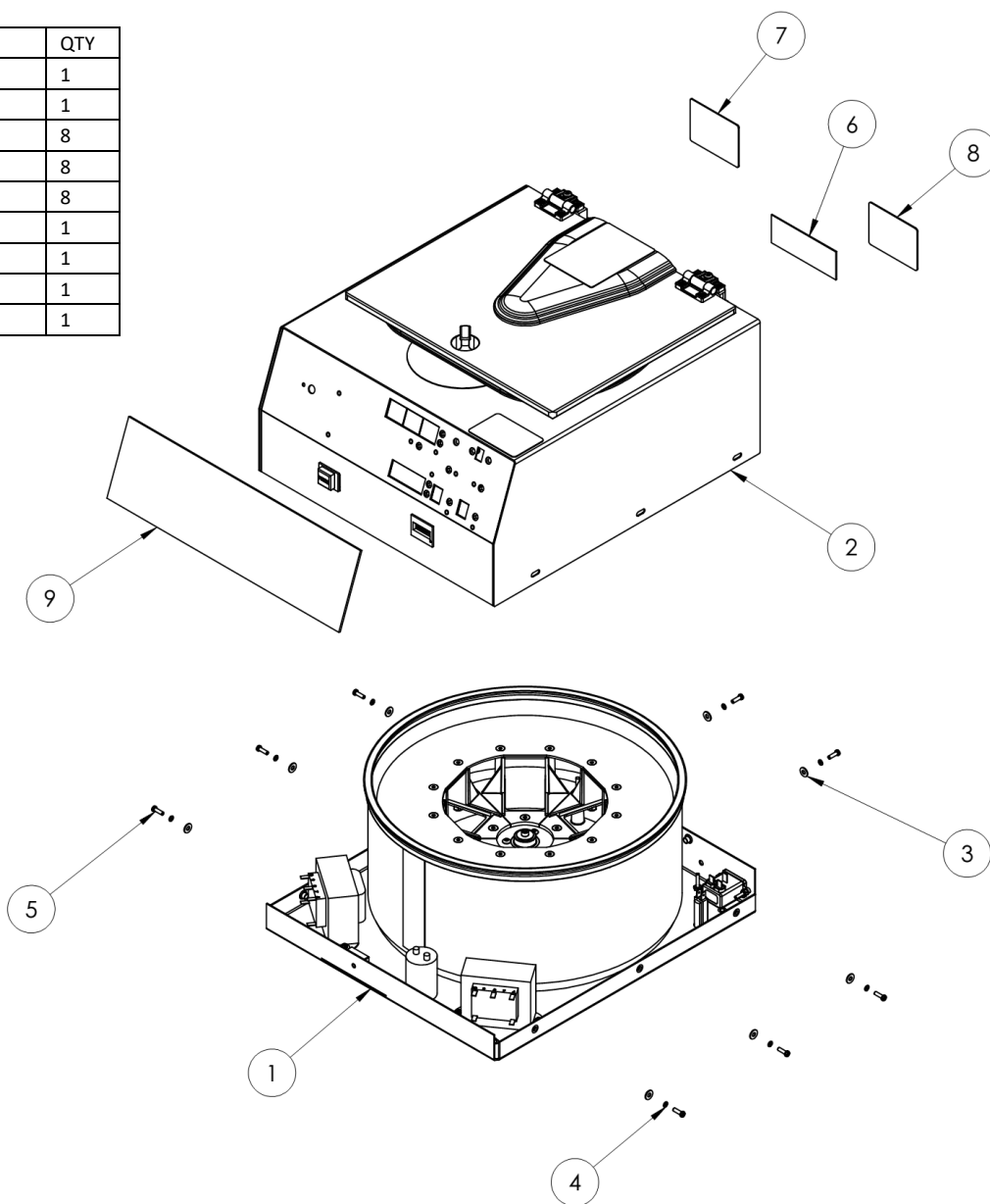

10 CABINET ASSEMBLY

ITEM NO.	PART NUMBER	DESCRIPTION	QTY
1	7710171	755VES CABINET, POWDER COATED	1
2	7717049	CYCLE COUNTER	1
3	7751072	755 Switch, Power, Illuminated	1
4	3051001	STUD, 6-32 x 7/8	11
5	7732018	MOTOR WELL GASKET	1
6	7745017	642/755 LID TRAY ASSEMBLY	1
7	3022002	NUT, 6.32, NYLOK, SILVER	11
8	3003002	STANDOFF, .320 x .203, 642 BOARD MOUNT	7
9	7728102	755 GROMMET, HEAT SINK MOUNT	2
10	7717041	VES PCB ASSEMBLY	1
11	3033002	WASHER, # 6 FLAT NYLON, WHITE	7
12	3033003	WASHER #8, FLAT, SILVER	2
13	3023001	NUT INSERT, 8-32 THREAD	4
14	7713007	0.062" KYDEX HINGE SPACER	2
15	7713003	HINGE SPACER	2
16	7724071	FRICTION HINGE	2
17	3012009	SCREW, 8.32 x 1.00, PAN HEAD, PHILLIPS, SILVER	4
18	02-002-1-0001	755 LID ASSEMBLY	1
19	3012004	SCREW, #6 x .375, PH/PHIL, SELF TAP, BLUNT, SILVER	4
20	OEM SPECIFIC	UNLOCKING INSTRUCTION LABEL	1
21	OEM SPECIFIC	LABEL, OPEN/CLOSE	1
22	OEM SPECIFIC	LABEL, STOP	1

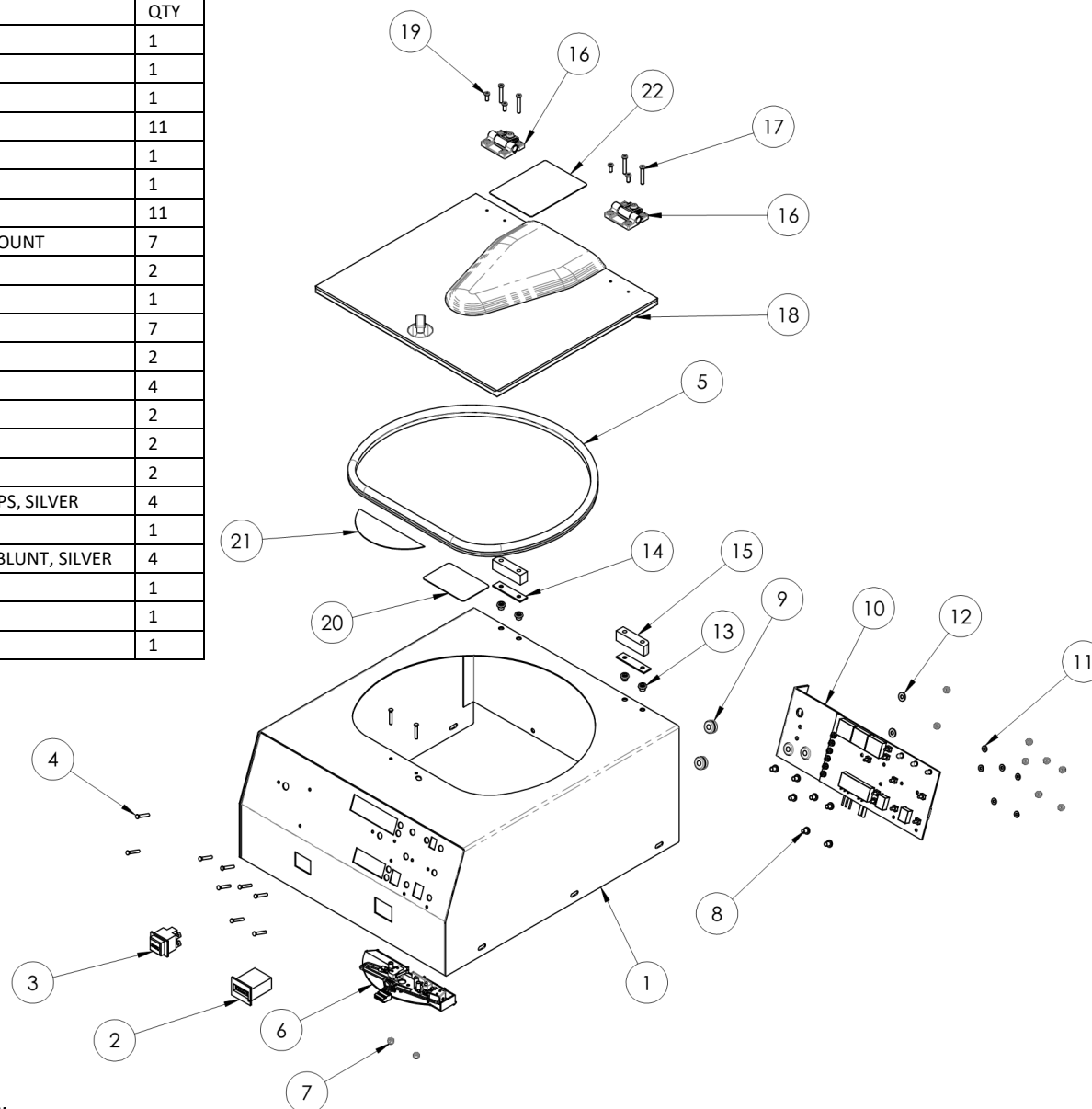

11 LOWER ASSEMBLY

ITEM NO.	PART NUMBER	DESCRIPTION	QTY
1	7710170	755VES Cabinet Base	1
2	3051001	STUD, 6-32 x 7/8	4
3	3023001	NUT INSERT, 8-32 THREAD	19
4*	3056002*	TRANSFORMER, 115V TO 16V*	2*
4**	3056004**	TRANSFORMER, 230V TO 16V**	2**
5	7728052	708/755 Feet, Rubber	4
6	7751043	BREAKER, 4A	1
7	7729003	842VES/853VES/755VES BRIDGE RECTIFIER	1
8	3003007	SPACER, LINE FILTER, ALUMINUM	2
9*	7751041*	642/755 LINE FILTER*	1*
9**	7751042**	642/755 LINE FILTER 230V**	1**
10	3022002	NUT, 6.32, NYLOK, SILVER	3
11	3033003	WASHER #8, FLAT, SILVER	17
12	3012007	SCREW, PHILLIPS, 8-32, 0.50 LONG	10
13	3033005	WASHER, #6, INTERNAL TOOTH	1
14	7729004	842VES/853VES/755VES POWER SUPPLY CAPACITOR	1
15	3021001	NUT, 6-32 HEX SILVER	1
16	3022005	NUT, M8, NYLOK, SILVER	1
17	3033001	#8 SPLIT LOCK WASHER	13
18	3012006	SCREW, 8-32 x 0.375, PAN HEAD PHILIPS, SILVER	7
19	7710350	755 Guard Bowl/Motor Mount Assembly	1
20	7713027	614/642/643/755 EXHAUST AIR DEFLECTOR	1
21	7786015	6 PLACE STANDARD ROTOR	1
22	3012033	SCREW, 10-32 X 1/2, SHCS	1
23	3033016	WASHER	1

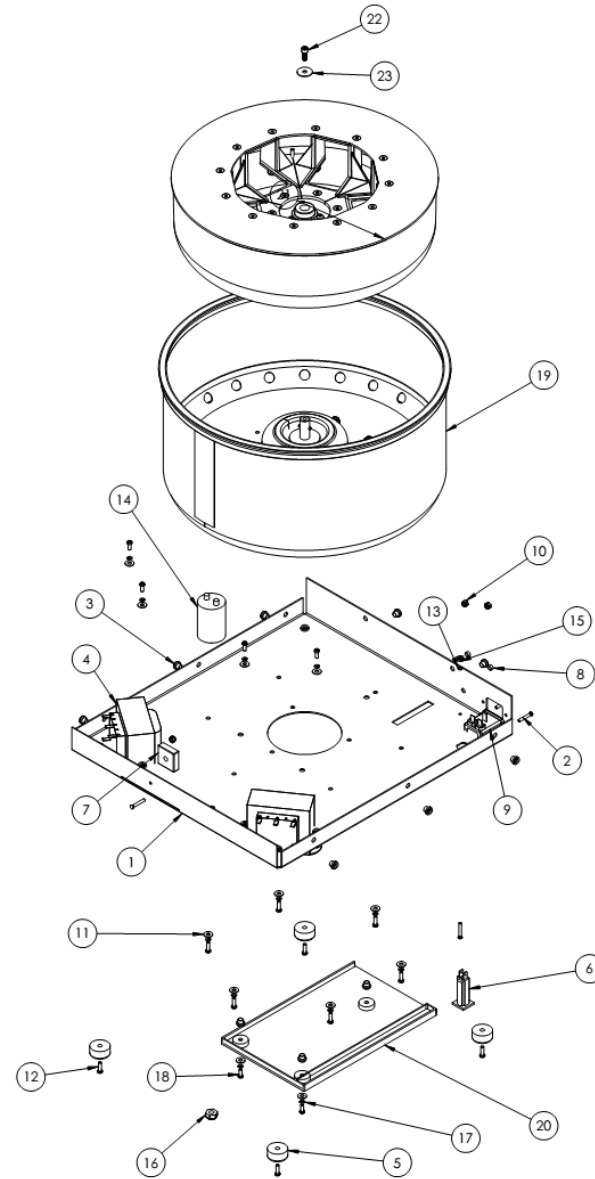

* ONLY USED IN 115V CENTRIFUGES

** ONLY USED IN 230 V CENTRIFUGES

